

# JVC

## SERVICE MANUAL

### COMPACT DISC AUTOMATIC CHANGER

## CH-X400 / CH-X450

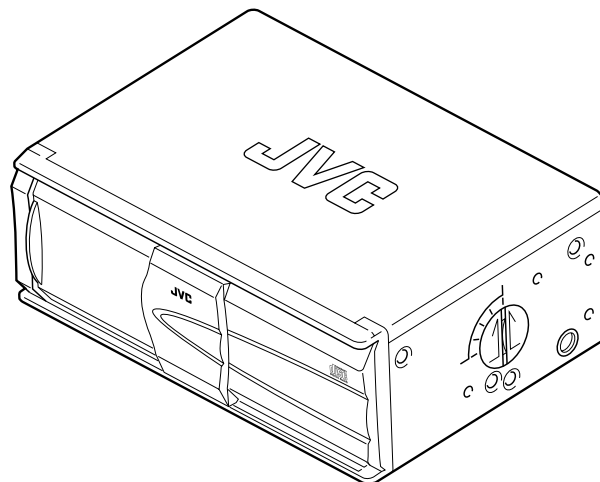

**COMPACT**  
**disc**  
**DIGITAL AUDIO**

#### Area Suffix

#### CH-X400

J ----- Northern America  
E --- Continental Europe

#### CH-X450

U ----- Other areas

### Contents

Safety precaution .....	1-2	Troubleshooting .....	1-20
Important for laser products .....	1-3	Wiring connections .....	1-26
Location of main parts .....	1-4	Pickup replacement procedure .....	1-27
Removal of main parts .....	1-5	Description of major ICs .....	1-29
JC 12 Forced eject procedures .....	1-19		

## Safety precaution

 **CAUTION** Burrs formed during molding may be left over on some parts of the chassis. Therefore, pay attention to such burrs in the case of performing repair of this system.

 **CAUTION** Please use enough caution not to see the beam directly or touch it in case of an adjustment or operation check.

# Important for laser products

## 1. CLASS 1 LASER PRODUCT

**2. DANGER :** Invisible laser radiation when open and interlock failed or defeated. Avoid direct exposure to beam.

**3. CAUTION :** There are no serviceable parts inside the Laser Unit. Do not disassemble the Laser Unit. Replace the complete Laser Unit if it malfunctions.

**4. CAUTION :** The compact disc player uses invisible laserradiation and is equipped with safety switches which prevent emission of radiation when the drawer is open and the safety interlocks have failed or are defeated. It is dangerous to defeat the safety switches.

**5. CAUTION :** If safety switches malfunction, the laser is able to function.

**6. CAUTION :** Use of controls, adjustments or performance of procedures other than those specified herein may result in hazardous radiation exposure.

**⚠ CAUTION** Please use enough caution not to see the beam directly or touch it in case of an adjustment or operation check.

**WARNING :** Osynlig laserstrålning är denna del är öppnad och spärren är urkopplad. Betrakta ej strålen.

**VARO :** Avattaessa ja suojalukitus ohitettaessa olet alttiina näkymättömälle lasersäteilylle. Älä katso säteeseen.

**ADVARSEL :** Usynlig laserstrålning ved åbning , når sikkerhedsafbrydere er ude af funktion. Undgå udsættelse for stråling.

**ADVARSEL :** Usynlig laserstrålning ved åbning, når sikkerhedsbryteren er avslott. unngå utsettelse for stråling.

## REPRODUCTION AND POSITION OF LABELS

### WARNING LABEL

DANGER : Invisible laser radiation when open and interlock or defeated.  
AVOID DIRECT EXPOSURE TO BEAM (e)

ADVARSEL : Usynlig laserstrålning ved åbning , når sikkerhedsafbrydere er ude af funktion. Undgå udsættelse for stråling. (f)

WARNING : Osynlig laserstrålning är denna del är öppnad och spärren är urkopplad. Betrakta ej strålen. (s)

VARO : Avattaessa ja suojalukitus ohitettaessa olet alttiina näkymättömälle lasersäteilylle. Älä katso säteeseen. (d)

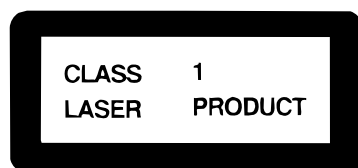

Caution.  
This production contains laser component of higher laser class than Class 1.

### Position And Reproduction Of Labels

Rear panel of the unit

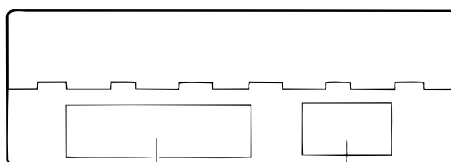

Name/Rating Plate

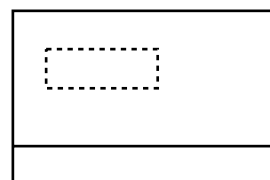

Top panel of the unit  
Geräteoberseite  
Panneau supérieur de l'appareil

## Location of main parts

### ■ Bottom view

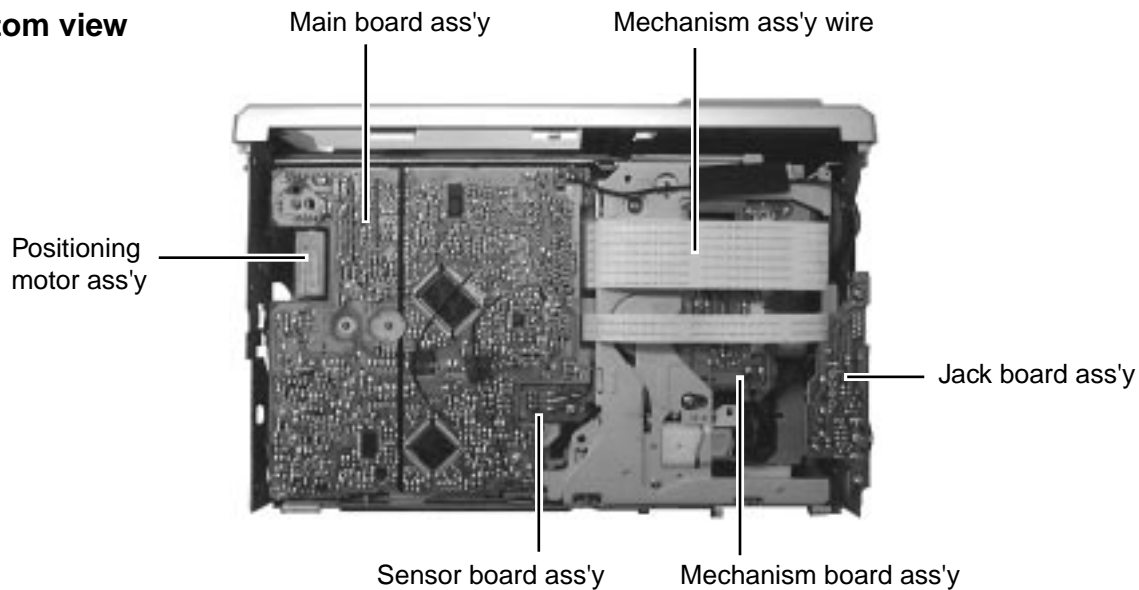

### ■ Top side view

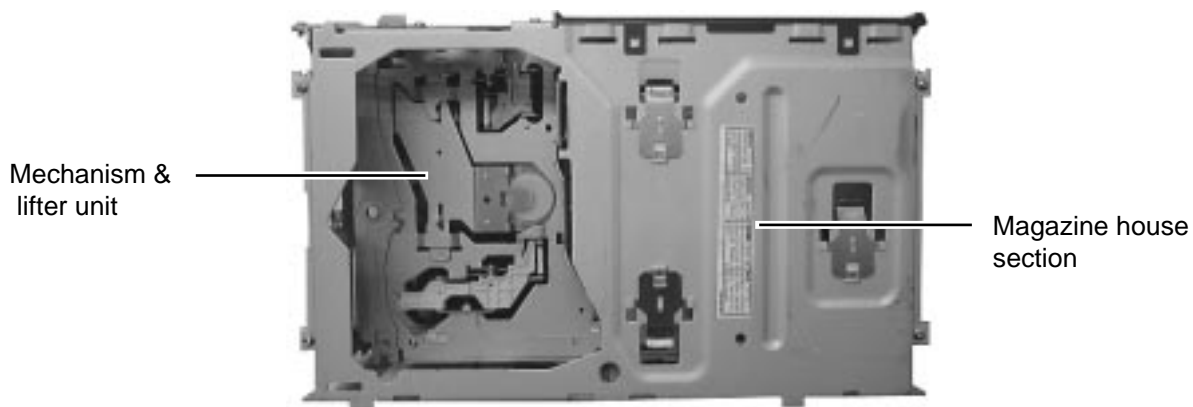

### ■ Remove the main board view

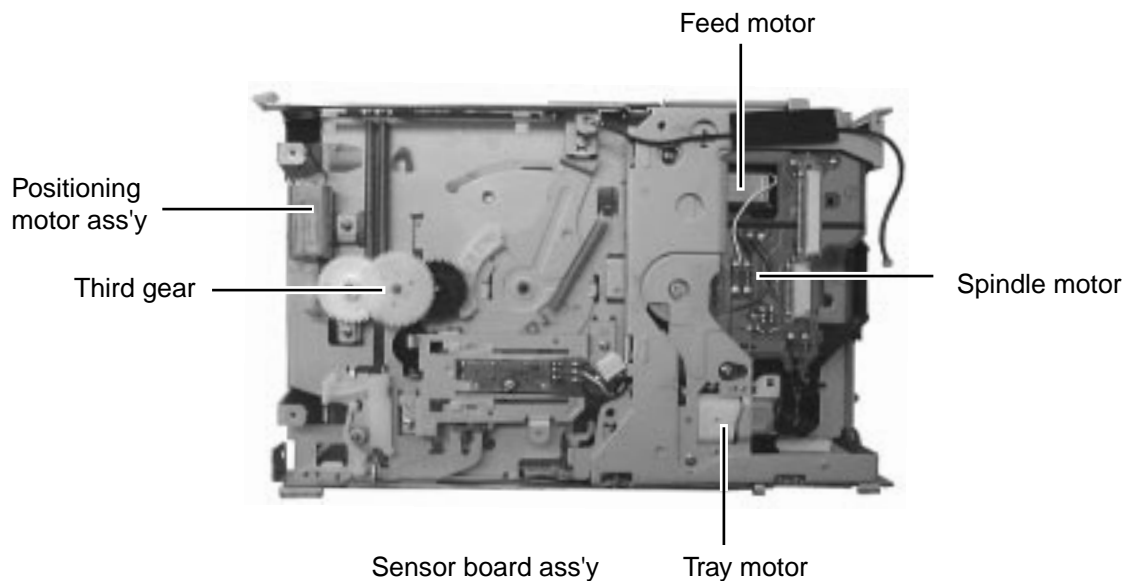

# Removal of main parts

## Disassembling procedures

Perform operations according to the items to be disassembled.

## Replacement of the Pickup

1. After removing the exterior (top and bottom)...
2. Proceed to the "Pickup Replacement" section.
3. When applying grease, refer to the Exploded View.  
Use new grease.

## Mechanism section

1. Remove the exterior (required section only).
2. The mechanism section is designed so that each unit can be removed separately.
3. When reassembling, refer to the assembling precautions.  
(Use new grease when applying grease.)

## Exterior section

### Removing the bottom cover and front panel assembly

1. Remove the screw (1-a) to unlock the mounting direction knob located on the side of the main unit.
2. Turn the mounting direction knob in the direction of the arrow using a coin, etc. to remove it. (The knob can be removed only when it is set to this position.)
3. Remove the four top cover fixing screws (1) at the triangle (A) marks on the side of the main unit. (Perform the same operation on both sides.)
4. Turn the unit upside down so the bottom surface is facing upward.
5. Lift the rear edge of the bottom cover slightly and lift the side by grasping the DIN jack section on the side panel, then turn it toward the front (raise upward) to remove the bottom cover.
6. Unhook the four catches located on both sides of the front panel, and turn the front panel toward the top cover (lower down) to remove the front panel.

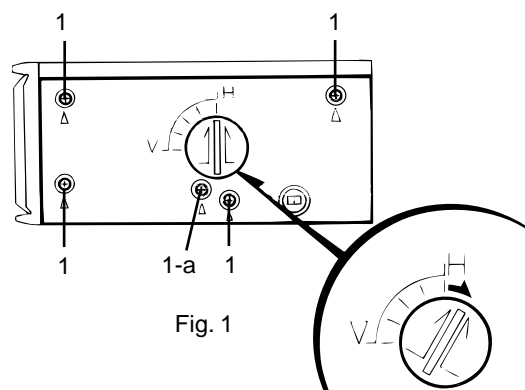

Fig. 1

Remove 1-a and turn in the direction of the arrow.

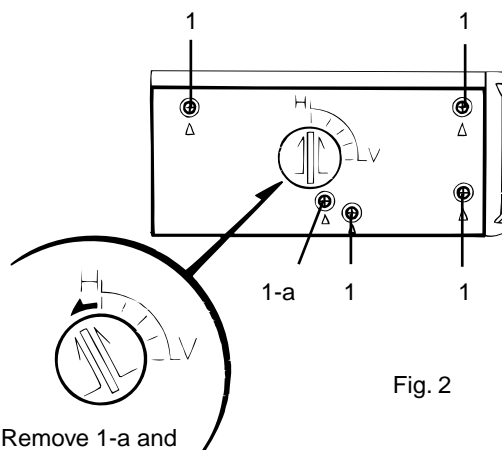

Fig. 2

Remove 1-a and turn in the direction of the arrow

The front panel can be separated by raising the cover.

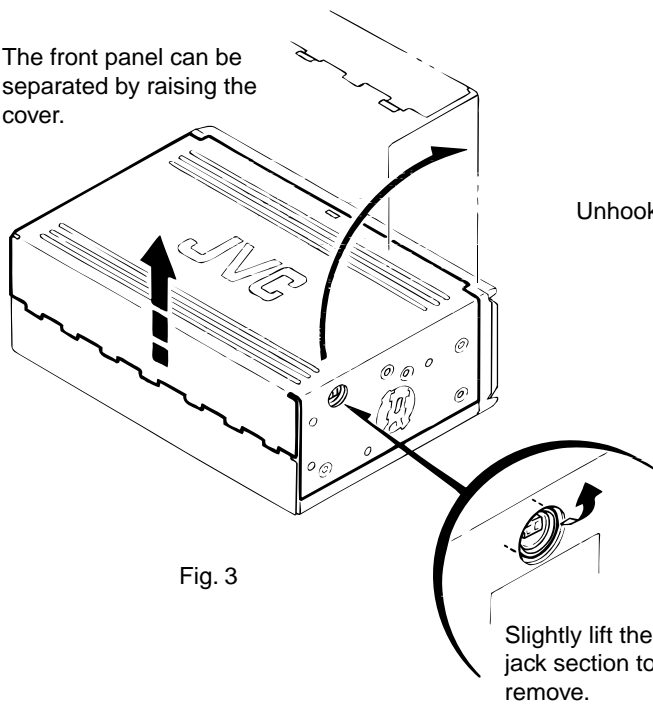

Fig. 3

Slightly lift the jack section to remove.

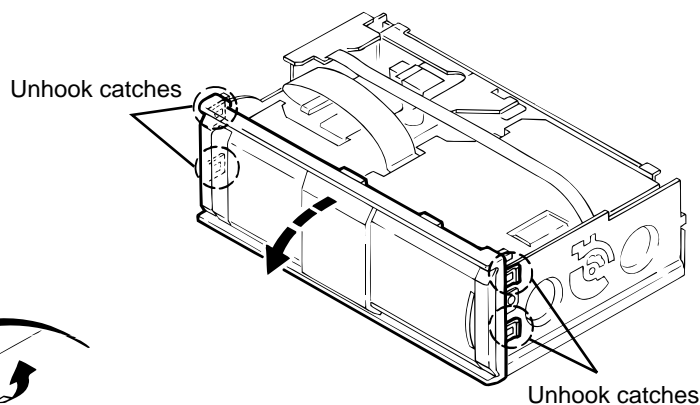

Fig. 4

## Removing the top cover

1. Pull out the dampers, being careful not to damage.  
When reattaching a damper, insert your finger to push out the center of the damper to mount it on the damper shaft, as shown in Fig. 6-1.
2. Turn the damper spring bracket toward the top at a right angle as shown in Fig. 7, then push down the lower side of the damper spring bracket to lift it off.
3. Remove the three fixing screws (3) and (4) on the DIN jack PCB assembly.
4. Lift the changer unit upward.
5. Remove the damper springs from the mechanism chassis if required. To reassemble, refer to the diagram below.

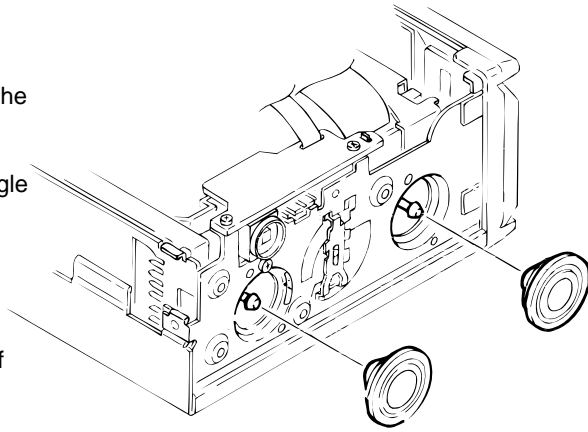

Fig. 5

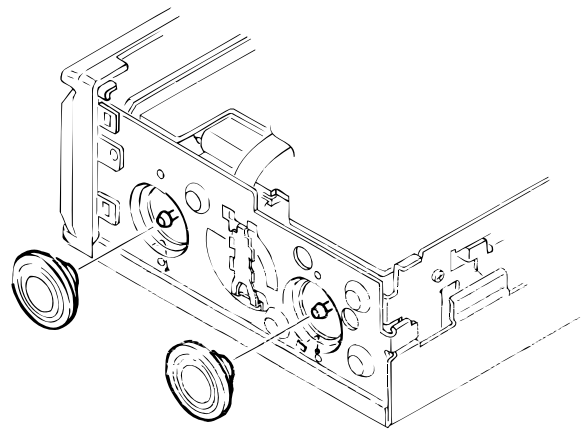
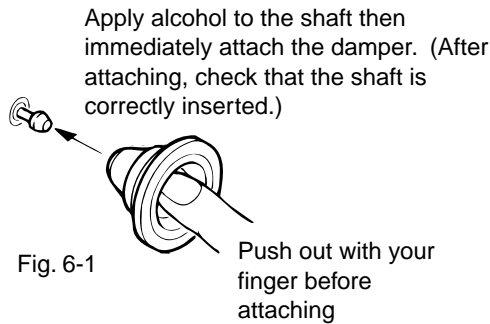
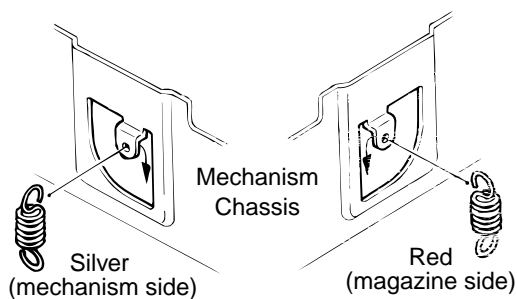
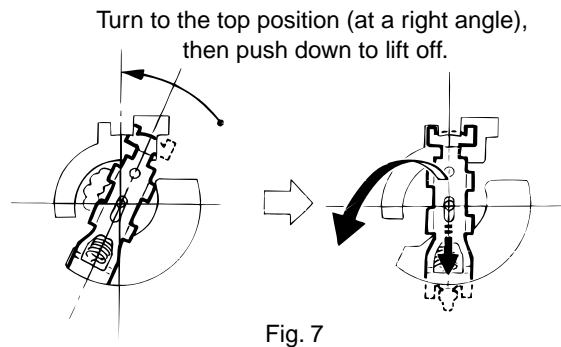
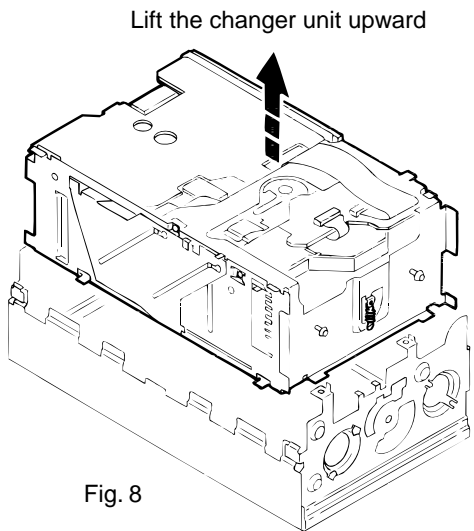
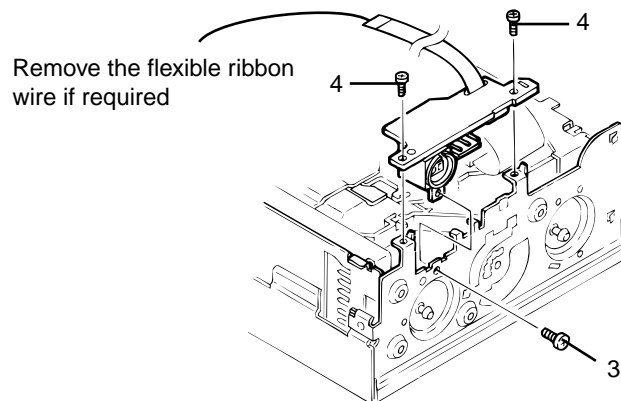

Fig. 6



### How to attach the damper springs

Fig. 8-1



## Removing the fittings

1. Remove the fixing screw (5).
2. Unhook the two catches (a) on the top edge of the fitting, then unhook the catches (b) at the left/right bottom edges.

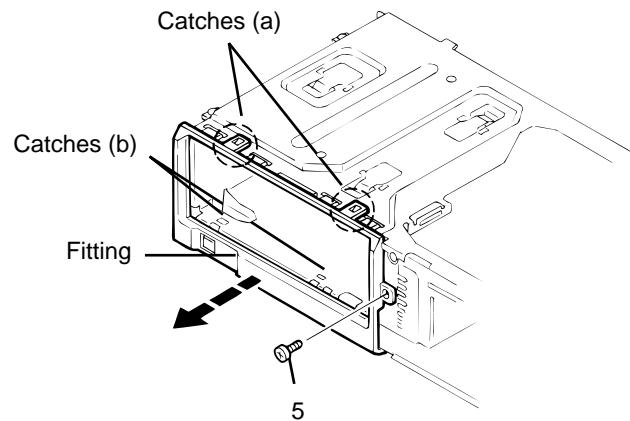

Fig. 10

## Removing the main PCB assembly

1. Remove the power IC fixing screw (6).
2. Remove the four screws (7) securing the main PCB assembly.
3. Disconnect position motor wire connector CN504 from the main PCB assembly.
4. Disconnect sensor PCB assembly wire connector CN601 from the main PCB assembly.
5. Remove the flexible ribbon wire from CN502 on the traverse mechanism PCB assembly.

When reinstalling the PC boards, refer to the reassembling procedures for protecting switches, etc.

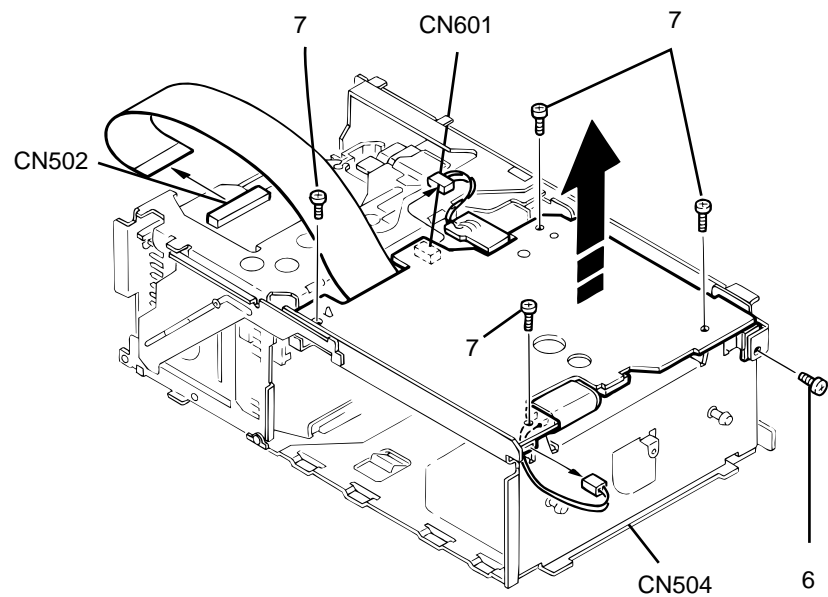

Fig. 11

## ■ Changer mechanism section

### Sensor assembly unit

1. Remove the two screws (1) securing the sensor assembly unit.
2. Unhook the springs on the back of the sensor assembly unit from the holes on the chassis.

### Magazine lock arm

1. Remove the magazine lock spring from the front side of the chassis.
2. Remove the poly-washer (b) securing the magazine lock arm.
3. Turn the magazine lock arm in the direction of the arrow until the notch is at the "C" position to remove it from the chassis.

### Positioning motor assembly

1. Remove the two screws (2) securing the positioning motor.
2. Slightly lift the positioning motor assembly to remove it from the two burrs on the chassis.

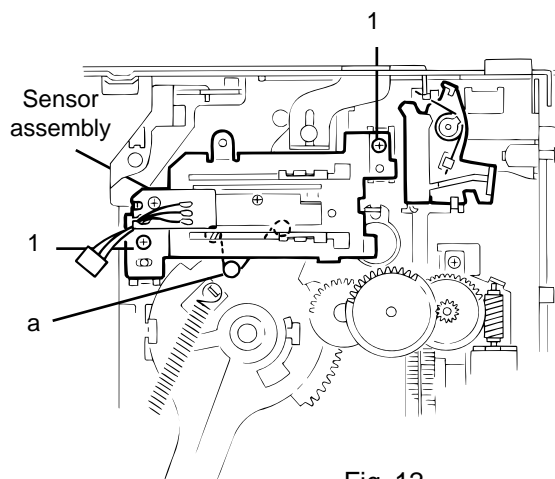

Fig. 12

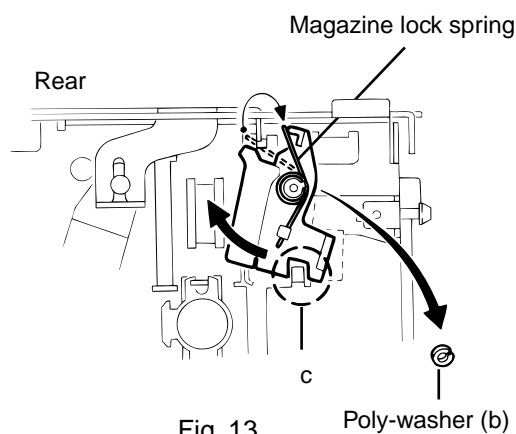

Fig. 13

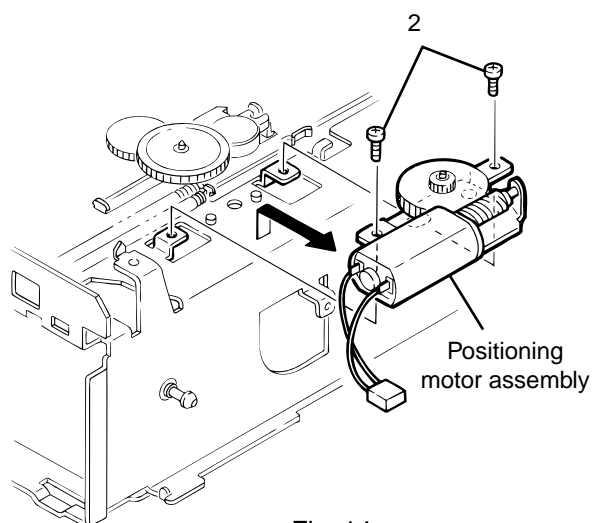

Fig. 14



### Rear slider

1. Position the unit with the front section facing down. Rotate the third gear located on the back of the main unit in the direction of the arrow (clockwise).
2. Shift the rear slider in the direction of the arrow and remove it at the rear slider mounting position (at the widest hole).

### Front slider

1. Position the unit with the rear section facing down. Rotate the third gear located on the bottom of the unit in the direction of the arrow (clockwise) until the front slider is shifted to the outermost position.
2. Remove the E-washer securing the front slider to remove the front slider from the chassis.

### Top plate

1. Remove the nine screws (3) securing the top plate.
2. Disconnect the section (e) attached to the rear of the unit, then lift the top plate slightly.
3. Slide the top plate toward the rear of the unit to remove the upper rod from the top plate.

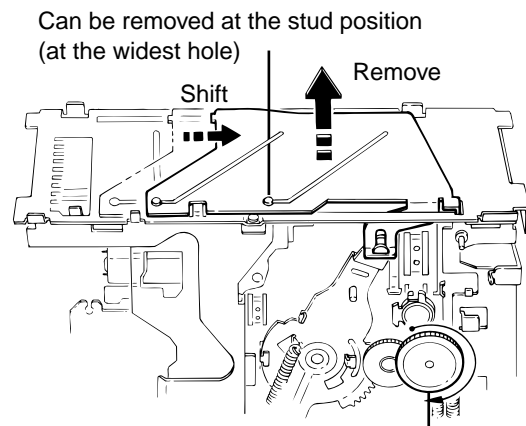
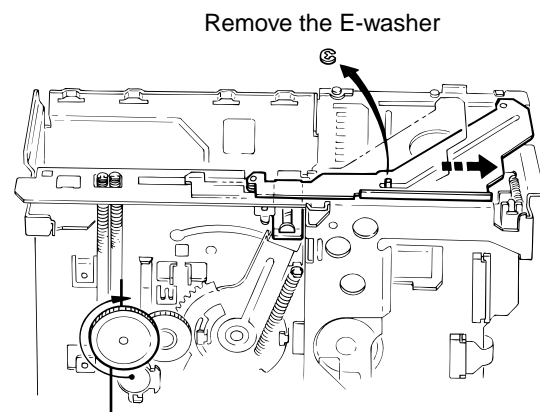

Fig. 15

Third gear



Third gear

Fig. 16

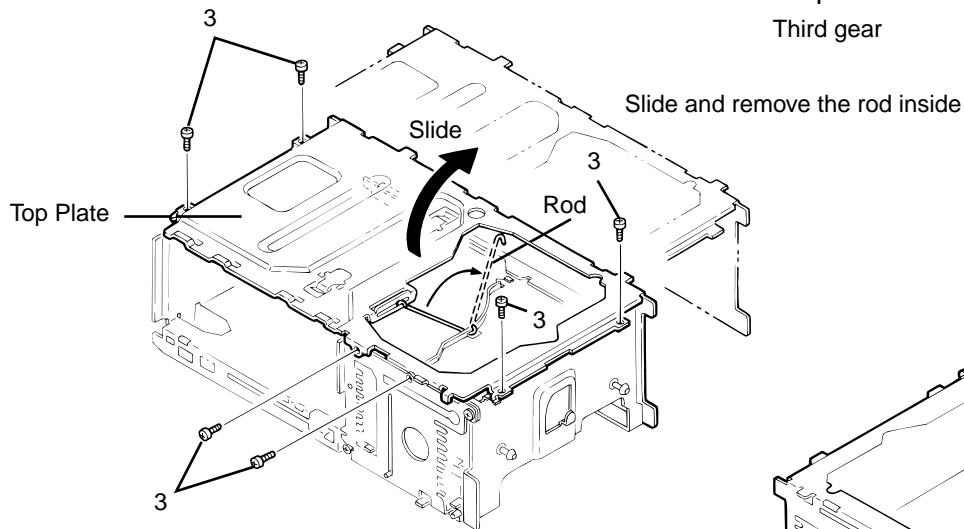

Fig. 17

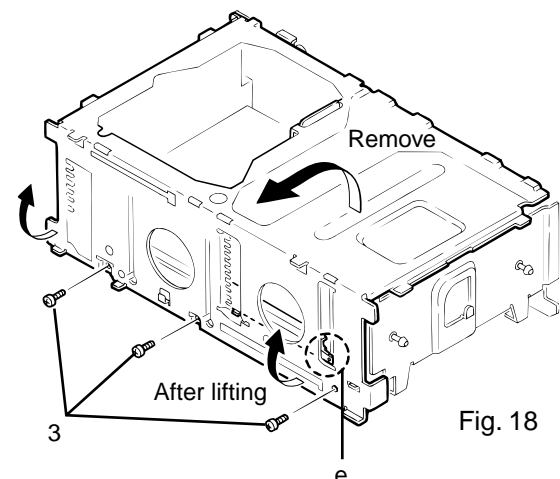

Fig. 18

**Lifter unit**

1. Unhook the elevator spring located on the front side of the unit.  
(Be sure to first unhook the spring from the lifter side as shown in the upper part of the diagram.)
2. Lift the lifter unit upward, then remove the lower rod to remove the lifter unit from the chassis.

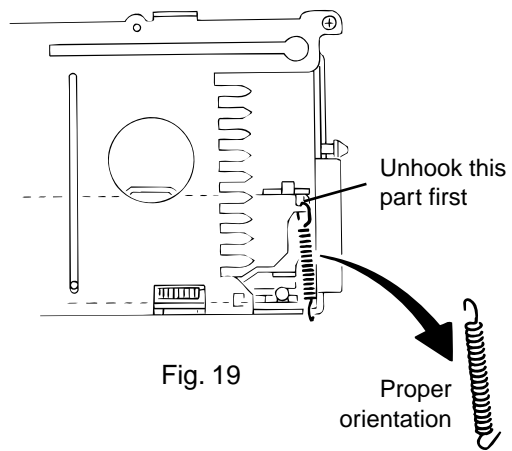

Fig. 19

**Lifter bracket**

1. Remove the two lifter bracket fixing screws (4) located on the back of the lifter unit.
2. Remove the lower rod.

**Side bracket and traverse mechanism**

1. Remove the two side bracket unit fixing screws (5) to disconnect the side bracket unit from the lifter unit.
2. Remove the three shafts on the traverse mechanism assembly from the lifter unit.

For reassembling, refer to the reassembling procedures.

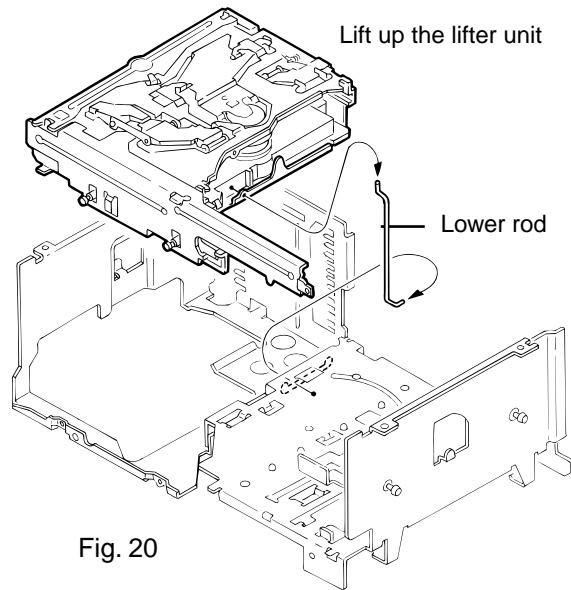

Fig. 20

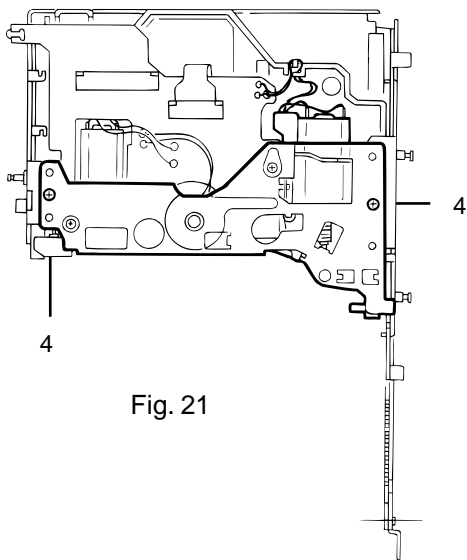

Fig. 21

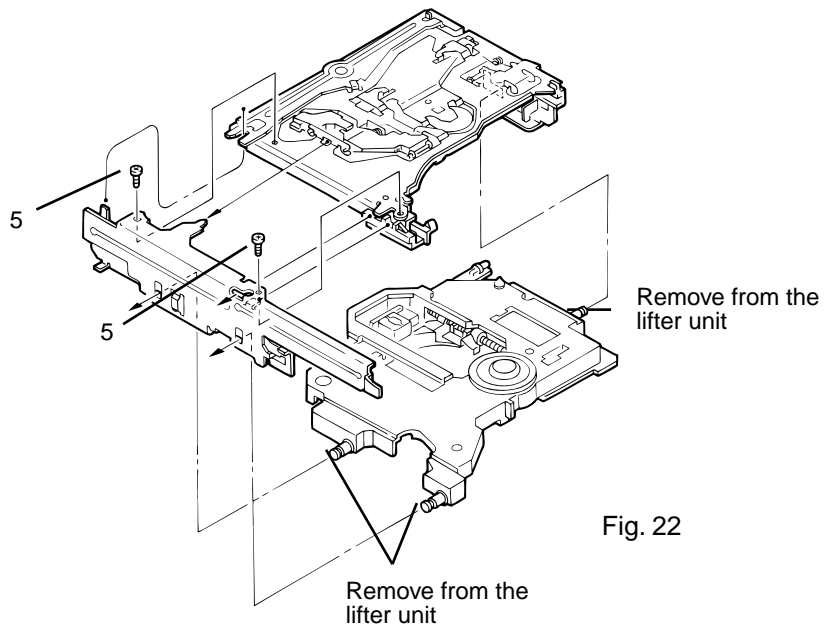

Fig. 22

## Pickup assembly

1. Remove the three mechanism PCB fixing screws (6) located on the back of the traverse mechanism.
2. Disconnect the two feed motor wires (blue and white), two spindle motor wires (red and black) and two tray motor wires (brown and black) that are soldered to the mechanism PCB assembly.
3. Short-circuit the grounding point on the mechanism PCB assembly, and lift it with the flexible PCB attached to connector CN501.  
Next, short-circuit the grounding point on the pickup unit and disconnect CN501.
4. Remove the screw (7) to remove the feed motor assembly.
5. Remove the screw (8) to remove the shaft holder retaining the feed slide shaft assembly and the middle gear.
6. Remove the middle gear.
7. Move the pickup assembly upward from the gear section and remove it from the traverse chassis assembly.
8. Remove the two screws (9) to remove the rack arm.
9. Pull out the feed slide shaft assembly.
10. Remove the screw (10) to remove the spring.

Note: Before replacing the pickup, be sure to short-circuit the grounding points. First short-circuit the PCB section and then immediately short-circuit the pickup section.

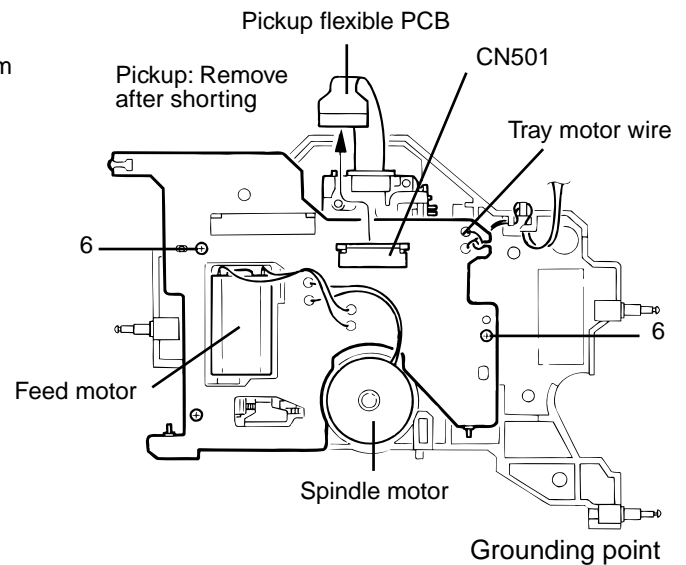

Fig. 23

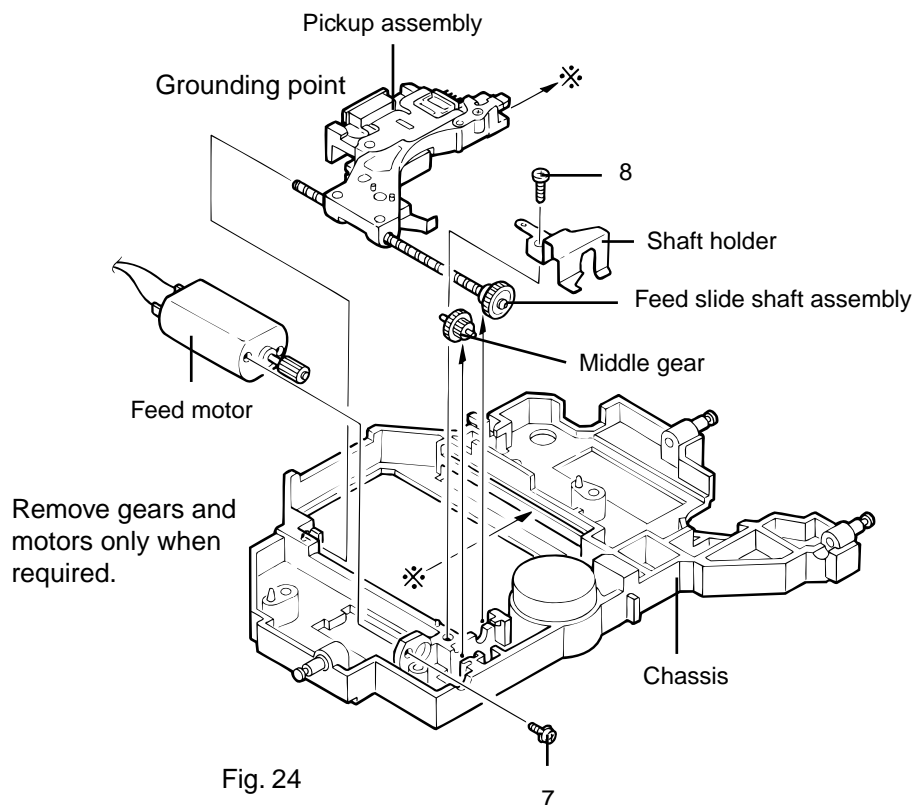

Fig. 24

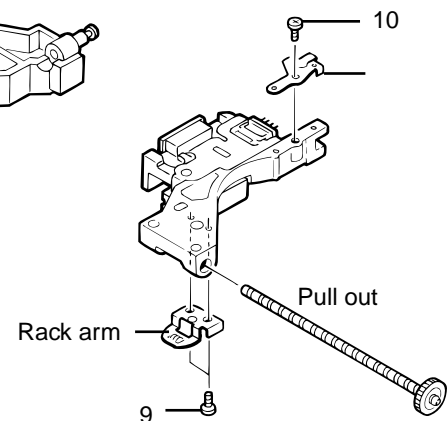

Fig. 25

### Tray motor

1. Remove the two screws (11) securing the tray motor.
2. Remove the two screws (12) to remove the tray motor assembly from the tray motor holder.

### Separation of the chassis L assembly and chassis R assembly

1. Remove the two screws (13) retaining the chassis "L" and "R" assemblies.
2. Slide the chassis L assembly toward the front and detach it, then remove the chassis "L" upward.

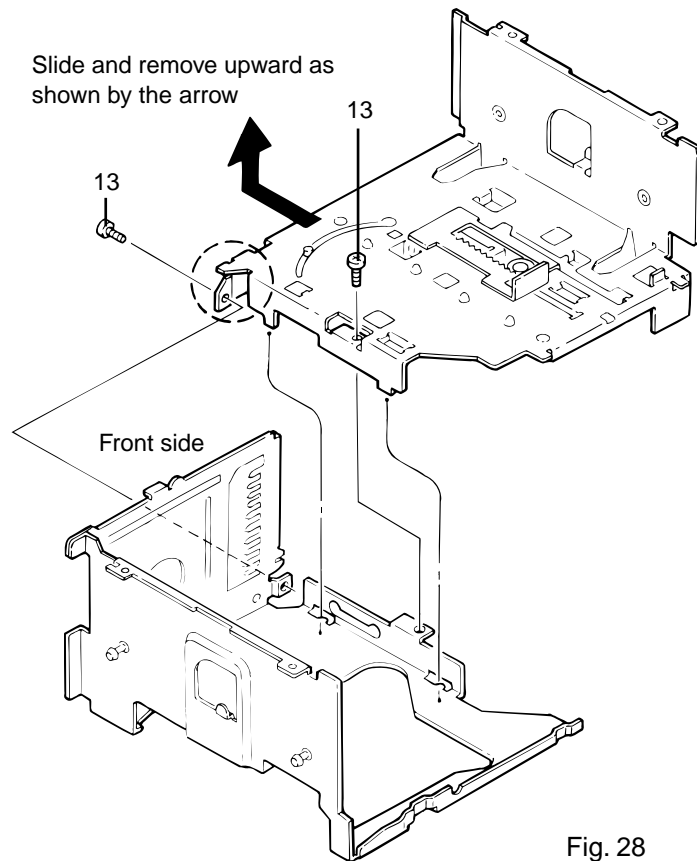
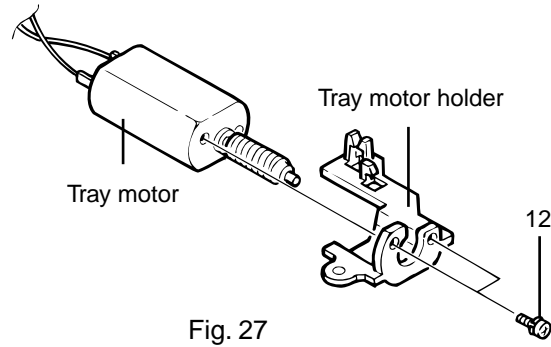
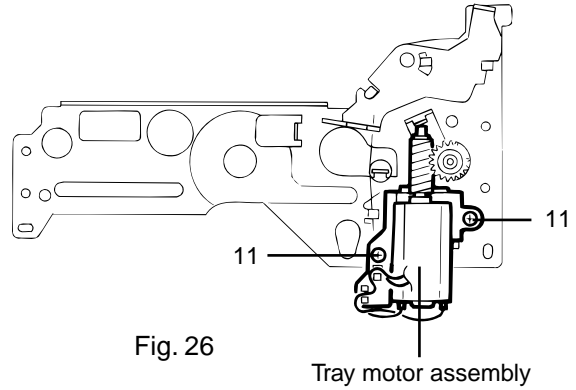

## Precautions on reassembling

When reassembling, also refer to the disassembling procedures.

### Mounting the traverse mechanism

1. When mounting the pickup assembly, attach the feed slide shaft assembly to the traverse chassis.  
Apply E-JC-525 grease to the shaft.
2. Mount the middle gear and the feed slide shaft to the traverse chassis and secure them with the screw (14) through the shaft holder.
3. Before mounting the mechanism PCB assembly, move the pickup to the outer edge position, then secure the PCB assembly using the screw (15).  
At this time, check that the rest switch is correctly placed.
4. To mount the rack arm, first move the pickup to the middle position and secure it with the screws (16).

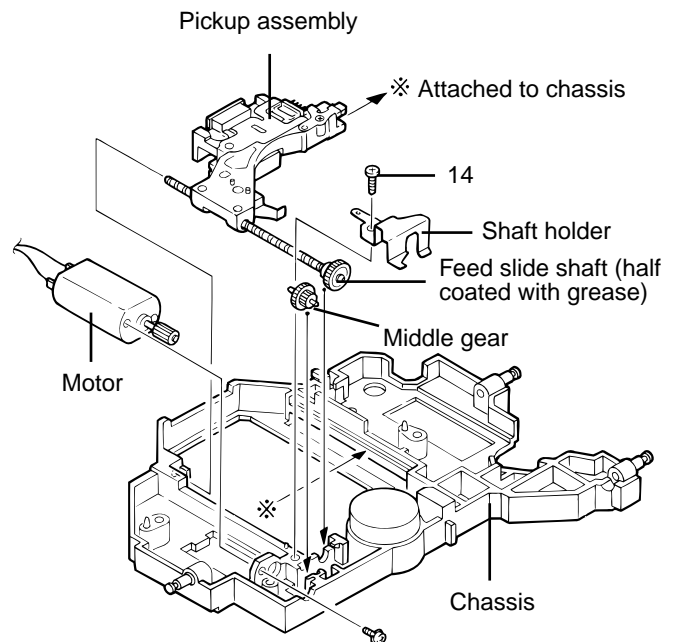

Fig. 29 Mounting the feed motor assembly

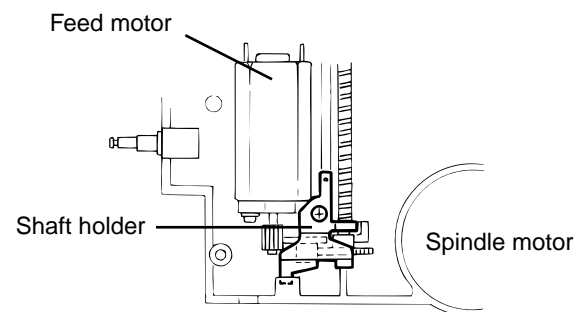

Fig. 30

### Mechanism PCB assembly

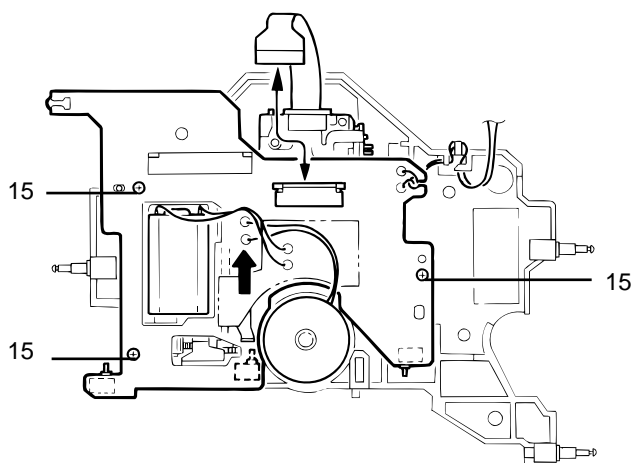

Fig. 31

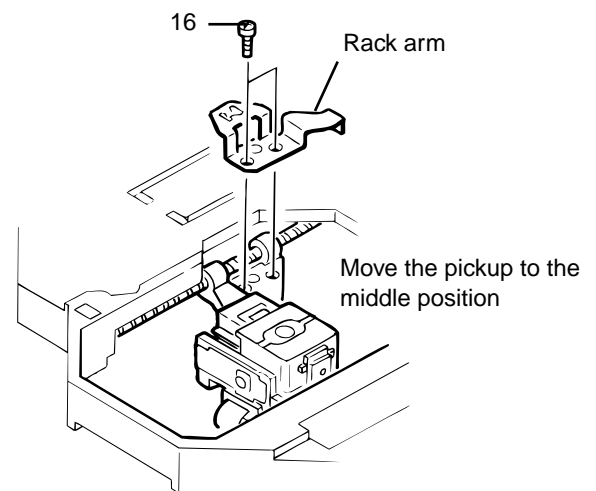

Fig. 32

### Mounting the lifter unit

1. Insert the shafts (B) of the traverse mechanism assembly into the slide grooves (F) on the lifter unit.
2. Shift the hook of the lifter unit to the edge, and shift the sliding lever inside the side bracket unit to the edge as well.
3. With each hole and lever shifted to the edge, mount the lifter unit and side bracket unit from the side.  
(Check each attached section, and check that the two shafts (C) of the lifter unit are correctly inserted into the holes (g) of the side bracket unit. After mounting, check that the levers move together.)
4. Turn the lifter unit upside down.  
As shown in Fig. 35, slide the lever 30 mm away from the edge, then mount the lifter bracket L assembly.

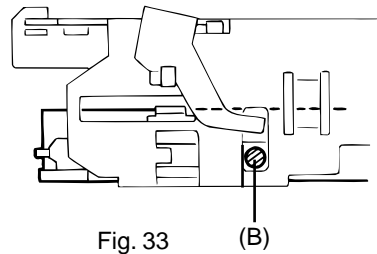

Fig. 33 (B)

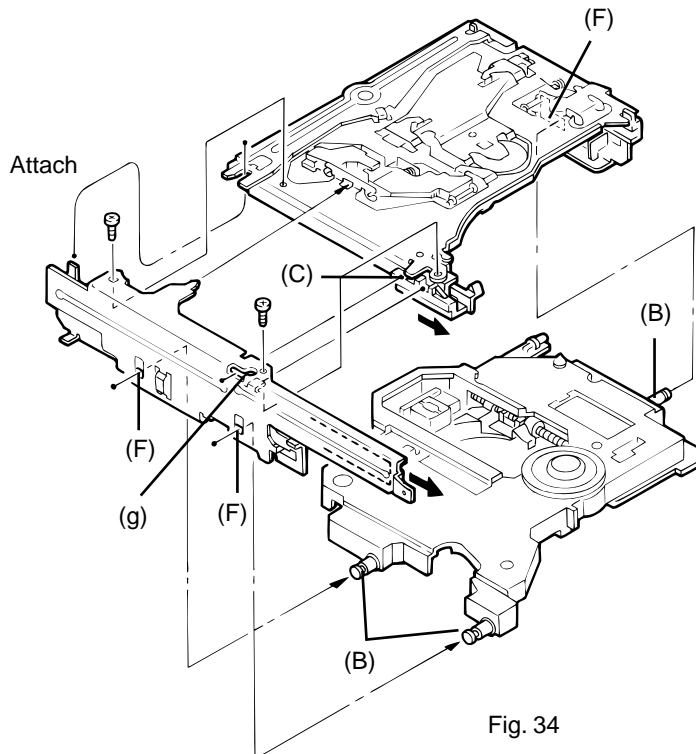

Fig. 34

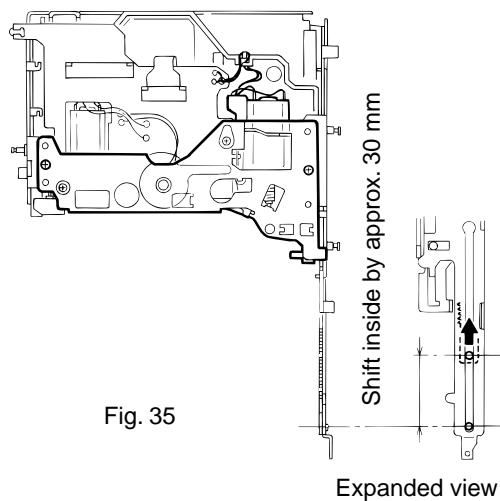

Fig. 35

Expanded view

## Connection of the chassis "L" assembly and chassis "R" assembly

1. Attach the lower rod to the chassis "R" assembly. While shifting the rod toward the front side, mount the rod on the lifter unit.  
With the rod mounted, place the lifter unit on the chassis "R" assembly.
2. Combine the chassis "L" and "R" assemblies so that the hook section (h) of the chassis "L" assembly is inserted into the notch of the chassis "R" assembly by sliding it from the front side.
3. After engaging, secure with the two screws (18).
4. Attach the tension spring between the lifter unit and the chassis.

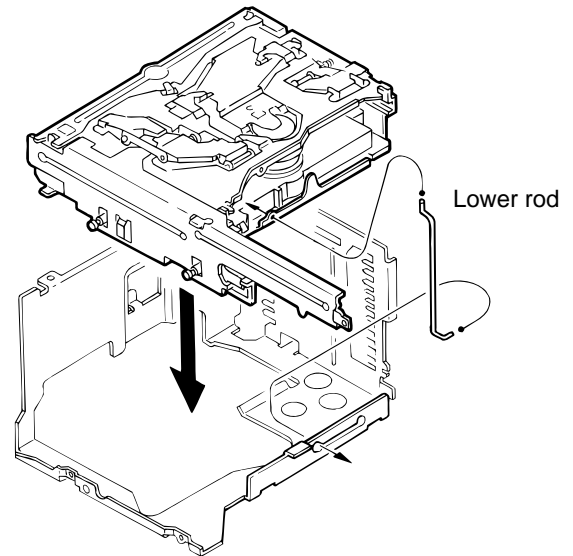

Fig. 36

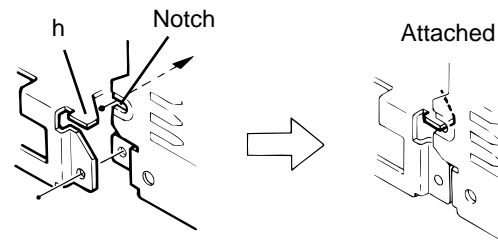

Fig. 37

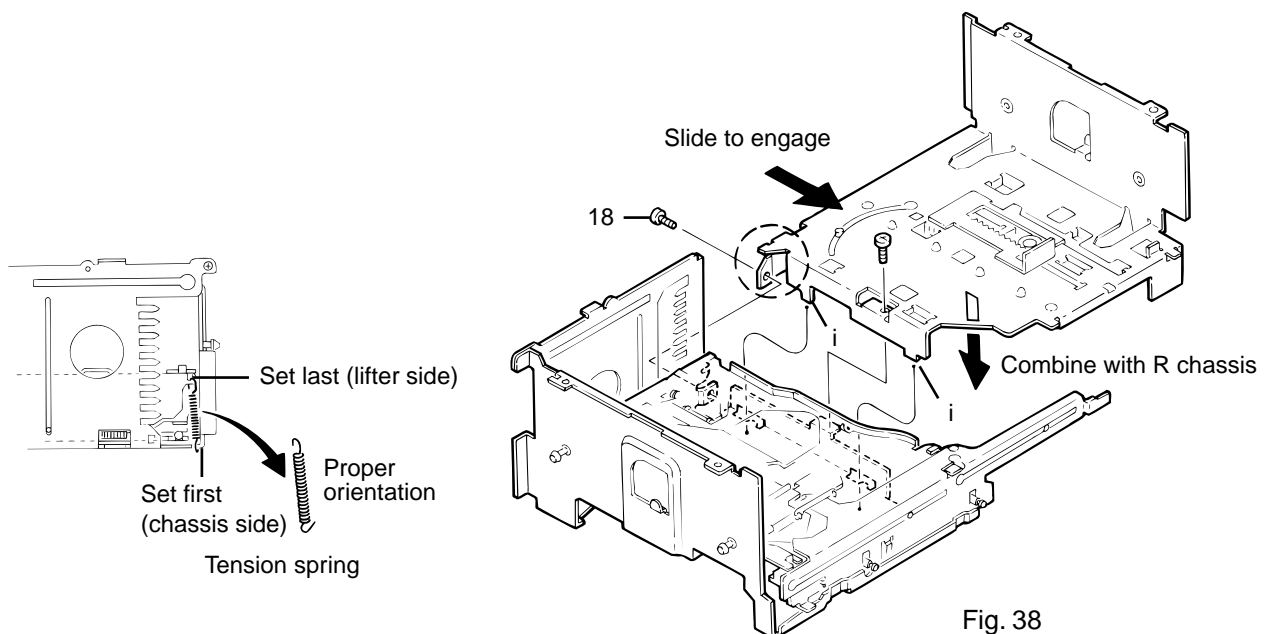

Fig. 38

### Mounting the top plate

1. Mount the upper rod on the lifter side (j) and set it on the rear of the top plate, then mount the other end of the upper rod to (k).
2. Check that the five points (l, m, n, o and p) are correctly positioned.  
When mounting section (q), set it so that section (D) of the lifter unit is pinched by the bending section of the top plate.
3. Secure the top plate with six fixing screws (19).

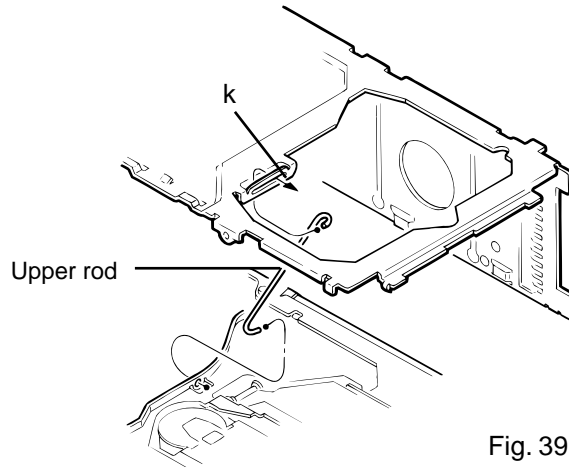

Fig. 39

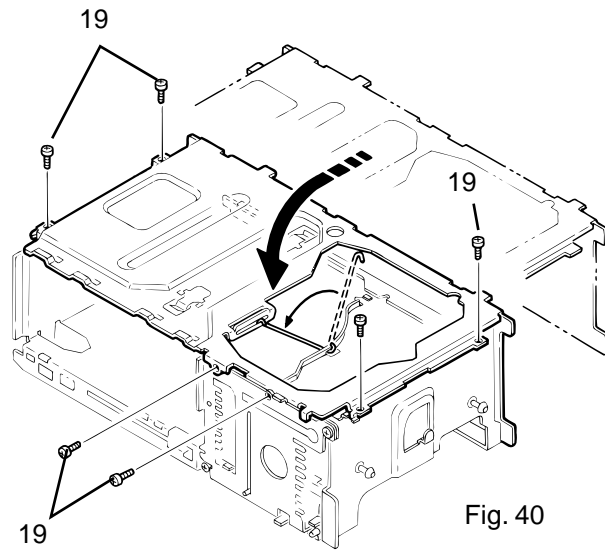

Fig. 40

#### Expanded view of mounting "q"

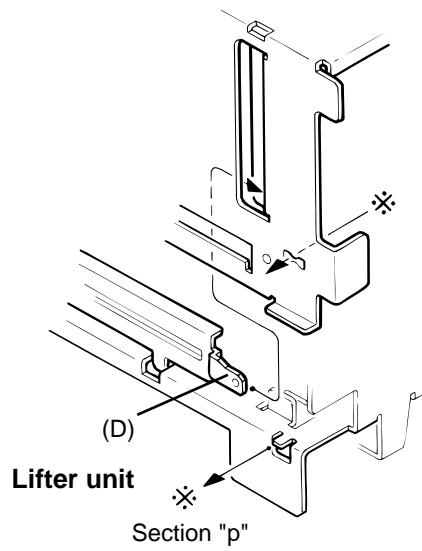

Fig. 41

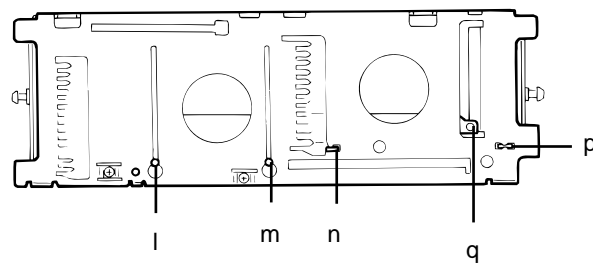

Fig. 42



**Mounting the front slider and rear slider**

- 1. Position the unit with the rear side facing down, then rotate the third gear in the direction of the arrow (clockwise) until the lift arm comes to the position at which the holes are exposed, as shown in Fig. 43-1.
- 2. Mount the front slider from the top.  
Rotate the third gear counterclockwise until the hole of the slider is lined up with the right hole of the stud, as shown in Fig. 43-2.
- 3. Mount the E-washer on the shaft.
- 4. Position the unit with the front side facing down, then mount the rear slider. Check that the (r), (s) and (t) positions are correctly mounted as shown in Fig. 44.
- 5. Rotate the third gear in the direction of the arrow (counterclockwise) until the lifter unit is at the top position.

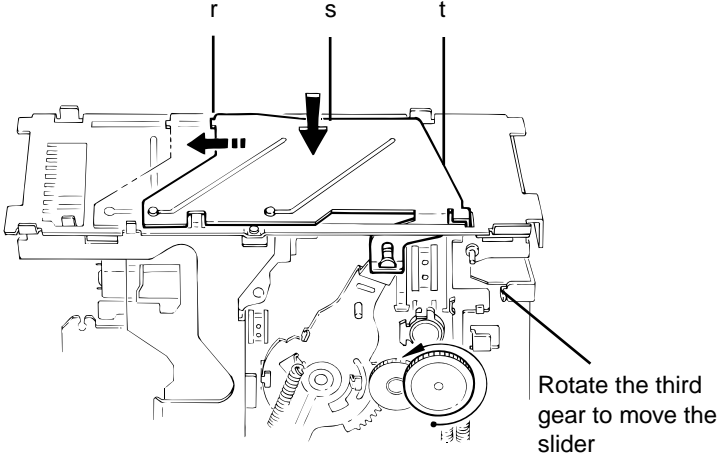
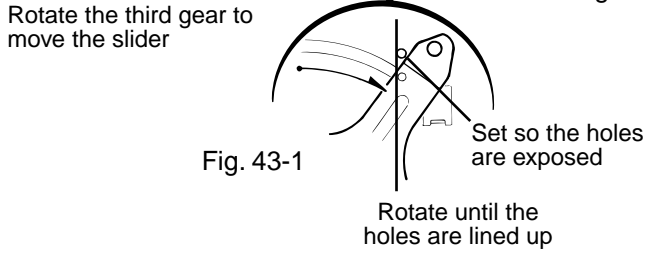
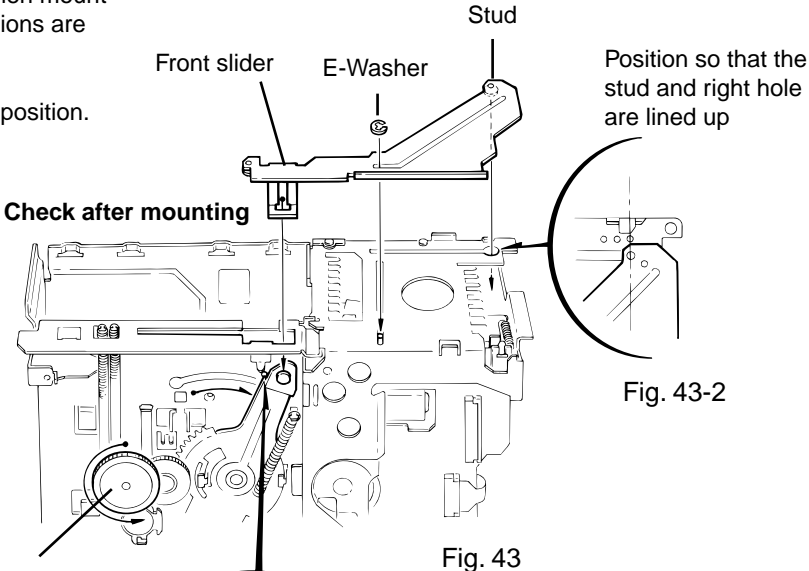

Fig. 44

**Mounting the sensor PCB assembly**

1. Attach the longer spring to the white resin, and attach the shorter spring temporarily to the sensor assembly bracket.
2. Mount the sensor assembly so that the shaft of the lift arm is inserted into the longer hole on the white resin located on the back of the sensor PCB assembly.
3. Attach the shorter spring to the hook of the lift arm.

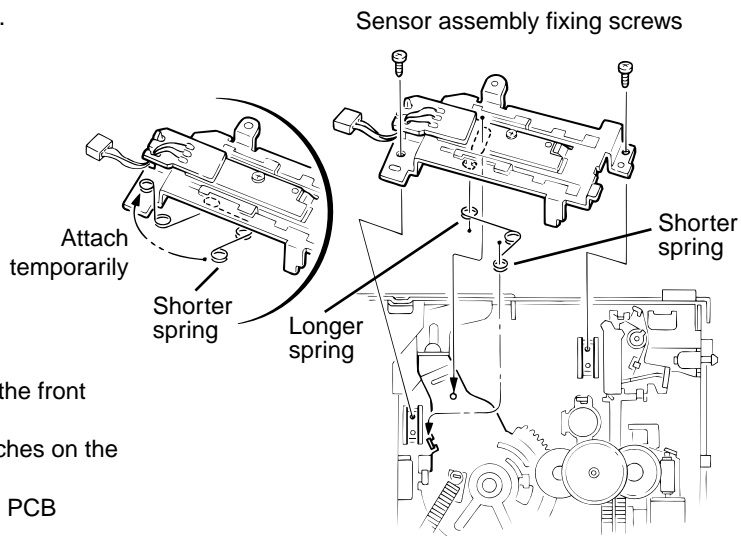

Fig. 45

**Mounting the main PC board assembly**

1. Rotate the third gear clockwise until section (E) of the front slider and the third hole from the right are lined up. (Be sure to set properly. If incorrectly set, the switches on the PCB assembly may be damaged.)
2. After they are correctly positioned, mount the main PCB assembly.

Position so that the slider hole and third hole from the right are lined up

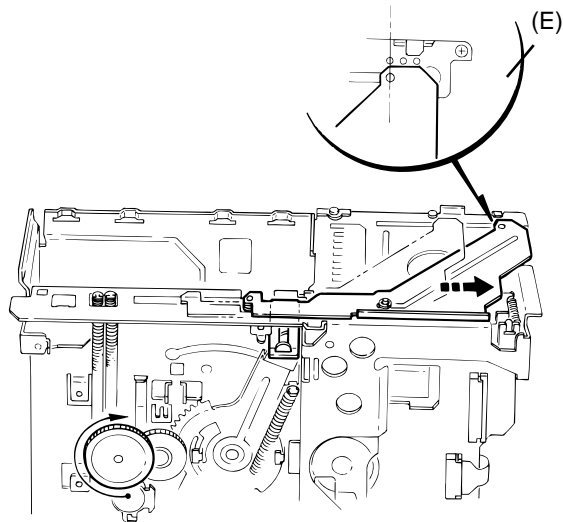
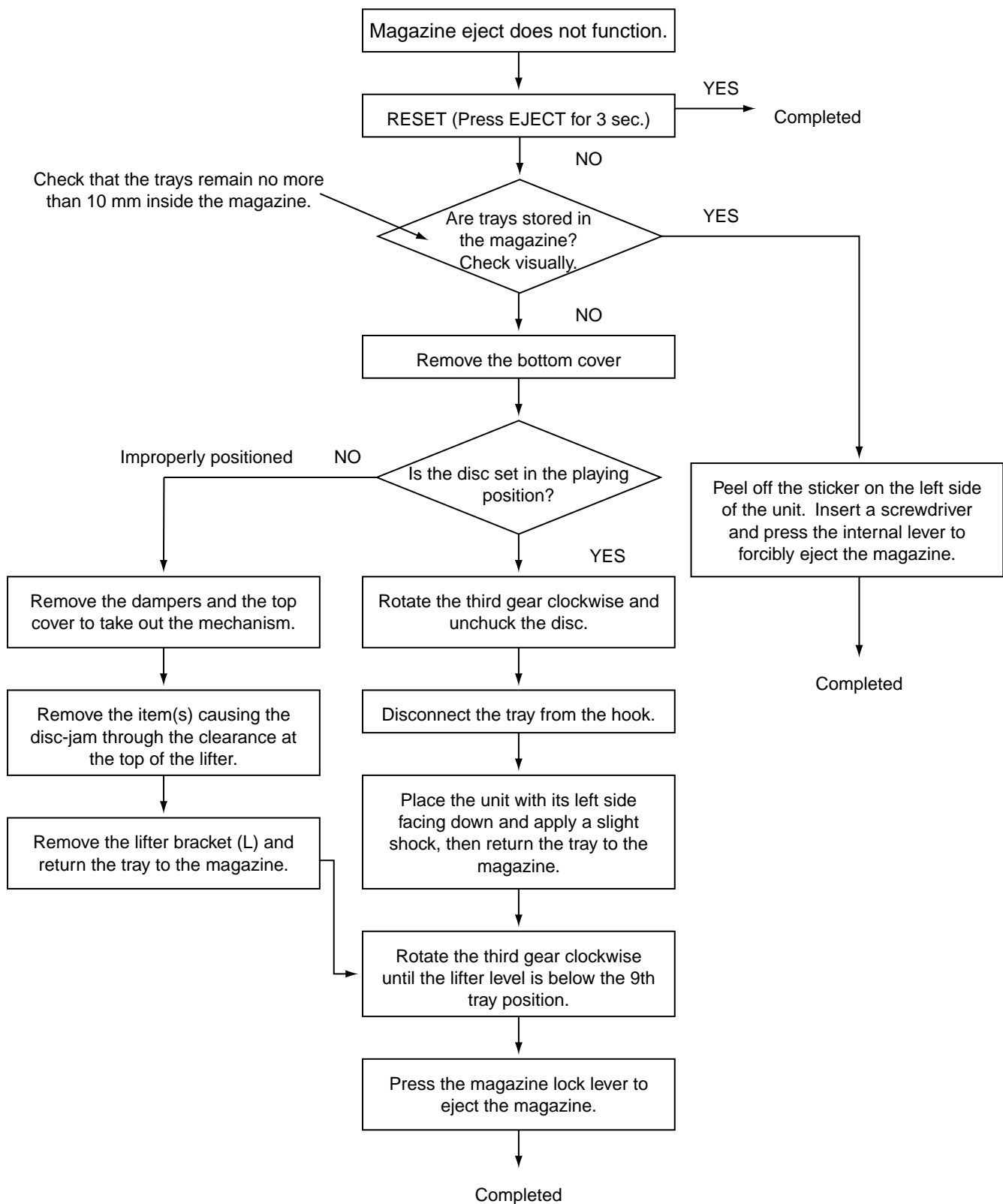

Fig. 46

## JC12 Forced eject procedures



# Troubleshooting

## ■ Servicing procedures for CH-X400 & CH-X450 error displays

Error display	Servicing procedure
E1: Eject error	<p>The magazine cannot be ejected until S601 (magazine switch) turns off. Can the magazine be ejected? YES → 1, NO → 2</p> <p>1 The magazine switch (S601) does not turn off even though the magazine is completely ejected. 2 Check that the magazine is not engaged with the mechanism assembly.</p>
E2: Position motor error	<p>The lifter does not move up and down when exchanging or ejecting discs. After resetting, check whether or not the lifter moves. YES → 3, NO → 4</p> <p>3 If the lifter exceeds the required disc position, check the lift position input. (IC601 pin 76) If the lifter does not reach the required disc position, check the mechanism (mainly the lifter elevation mechanism)</p> <p>4 Check that voltage is present at the motor terminal. If voltage is present, check the lifter elevation mechanism. If voltage is not present, separate the motor from the circuit and check again whether or not voltage is present. If voltage is present, next check that the armature resistance of the position motor (resistance between motor terminals) is approx. 12 Ω. If the resistance is excessively low (1 - 2 Ω), the motor is defective.</p>
E3: Tray motor error	<p>Trays cannot be opened or closed when exchanging or ejecting discs. Does the tray move when changing or ejecting discs? YES → 5, NO → 6</p> <p>5 Check that TRAY OUT SW (S602) and TRAY IN SW (S603) function correctly.</p>

	S602 & IC601 pin (46)	S603 & IC601 pin (45)
When opening	H	L
When closing	L	H

6 Check that the drive voltage is applied to the motor terminal.  
If the voltage is present, check the tray mechanism.  
If the voltage is not present, separate the motor from the circuit and check again whether or not the voltage is present.

E4: Pick returning error	<p>Does the feed (pickup unit) return to the inner area of the disc when ejecting? YES → 7, NO → 8, 9</p> <p>7 Check the rest switch. 8 If the feed gear is rotated, check the feed transfer mechanism 9 If the feed gear is not rotated, check the motor driver and the pattern.</p>
--------------------------	---

### Other errors occurring in the receiver or controller.

E8: Connection error	<p>When selecting the CD Changer mode using function keys, etc., the unit does not enter the CD changer mode, or the E8 error display appears. This signifies trouble relating to communications.</p> <p>a Check the connection cables between the CD changer and the receiver (CD changer controller). b Check the CD changer power cord and the fuse (including F901 on the PC board). c Check IC651 and its peripheral circuits.</p>
----------------------	---

★ The E1~E8 error displays described above may appear as E-1~E-8, 1E1~1E8, R-1~R-8, or RST1 ~RST8, depending on the product.

## CH-X400 & CX-H450 Error code

The following error codes can be displayed and stored in up to 3 memories when the KD-MX3000 is used with the controller. Refer to the KD-MX3000 service manual regarding error code indication.

The error code indication when using the earlier controller is the same as the CH-X99, KD-MK88 and other 12CD changer models.

**CH-1 error code table**

Generating condition		Description	Error code
<b>Tray extension error</b>	Tray-in switch time out (Tray-in switch Low, Tray-out switch High)	Tray stops part way	E1 03 00 11
	Tray-out switch time out (Tray-in switch High, Tray-out switch High)	Tray stops part way	E1 03 00 12
	Tray-in switch time out (Tray-in switch Low, Tray-out switch Low)	Tray-in switch faulty or other defect	E1 03 00 13
	MAG-in switch Low to High	Magazine removed when tray partly extende	E1 03 00 14
<b>Tray retraction error</b>	Tray-in switch time out (Tray-in switch Low, Tray-out switch Low)	Tray motor inoperative	E1 03 00 16
	Tray-out switch time out (Tray-in switch High, Tray-out switch High)	Tray retraction stops part way	E1 03 00 17
	Tray-in switch time out (Tray-in switch Low, Tray-out switch Low)	Tray-in switch faulty or other defect	E1 03 00 18
	MAG-in switch Low to High	Magazine removed when tray partly r etracted	E1 03 00 19
<b>Lifter raise error</b>	Wait position time out	Position motor inoperative	E1 02 00 21
	Wait position time out	Position not stable in fine adjust mode	E1 02 00 22
	Wait position time out	Other fault	E1 02 00 23
<b>Lifter lower error</b>	Wait position time out	Position motor inoperative	E1 02 00 26
	Wait position time out	Position not stable in fine adjust mode	E1 02 00 27
	Wait position time out	Other fault	E1 02 00 28
<b>Chuck error</b>	Play position time out	Position motor inoperative	E1 02 00 31
	Play position time out	Position not stable in fine adjust mode	E1 02 00 32
	Play position time out	Other fault	E1 02 00 33
<b>Unchuck error</b>	Wait position time out	Position motor inoperative	E1 02 00 36
	Wait position time out	Position not stable in fine adjust mode	E1 02 00 37
	Wait position time out	Other fault	E1 02 00 38
<b>Eject error</b>	Eject position time out	Position motor inoperative	E1 02 00 41
	Eject position time out	Eject position not attained	E1 02 00 42
	MAG in switch time out	Magazine not ejected	E1 02 00 43
<b>Initialize error</b>	Mechanism switch time out	Both Tray-in and Tray-out Low	E1 03 00 46
	Absolute position time out	Not stable at absolute position	E1 03 00 47

Note: The 1st error code is indicated by E1, while the 2nd and 3rd error codes are respectively indicated by E2 and E3.

■ Flow chart for reading TOC (Table of contents)

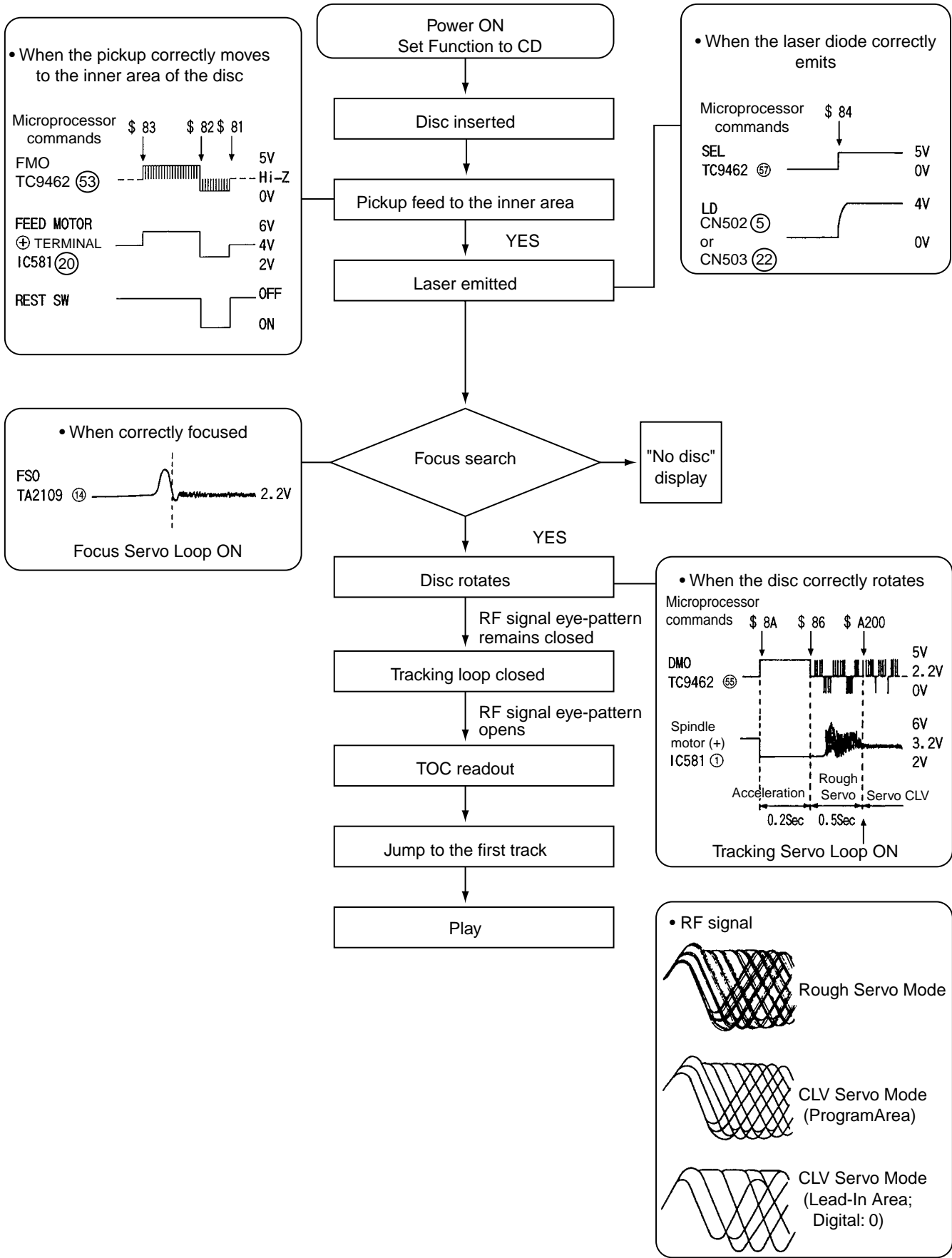

■ General section

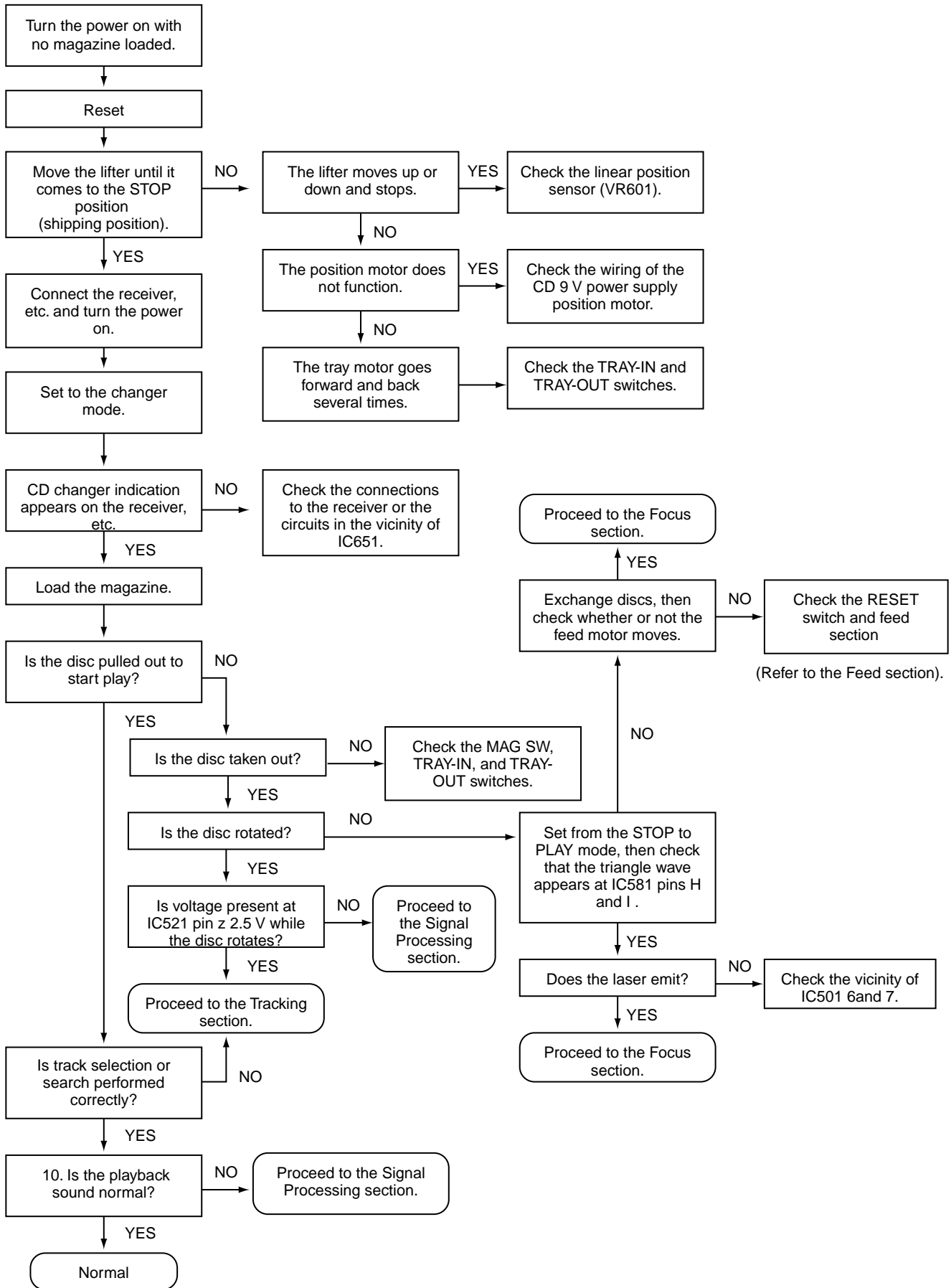

**Feed section**

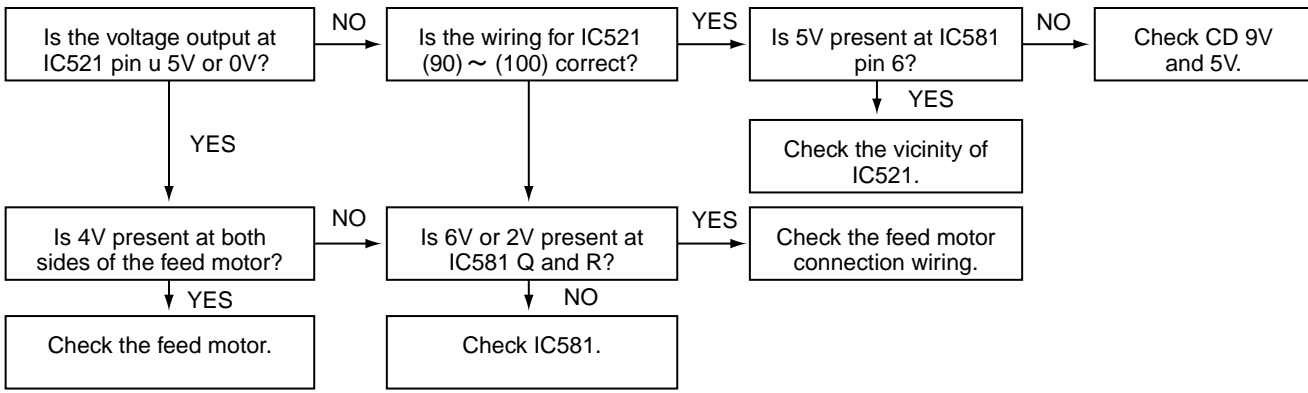

**Focus section**

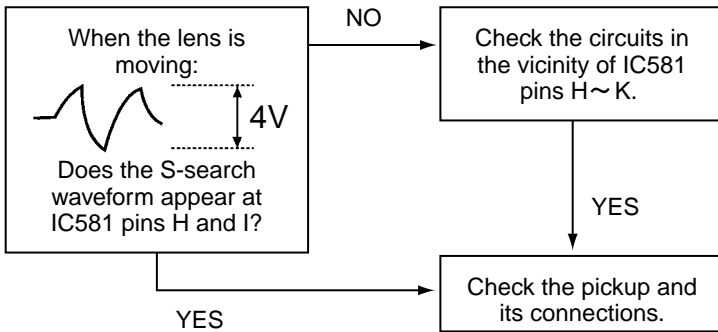

**Spindle section**

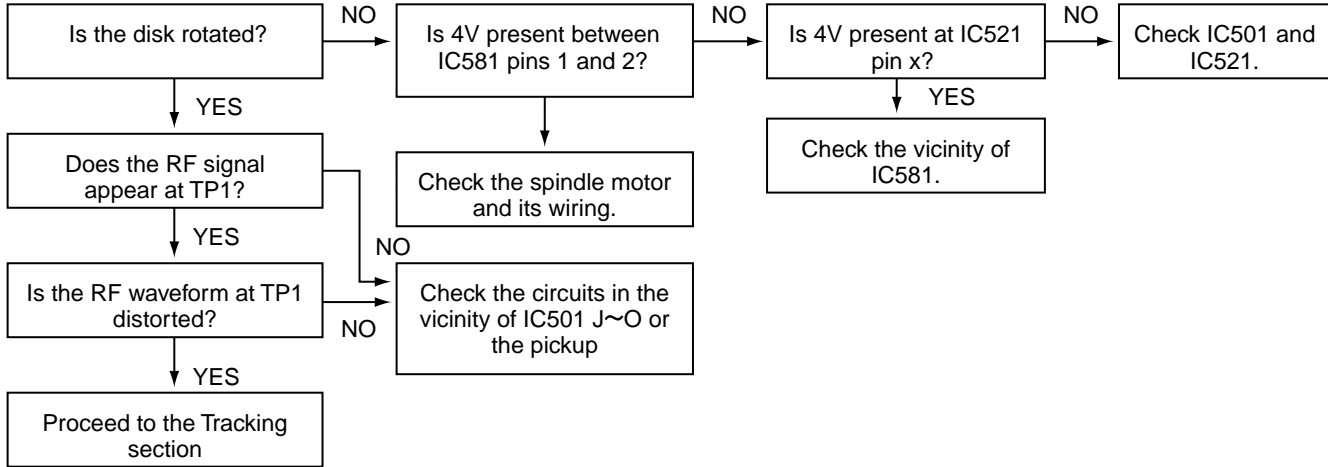

**Tracking section**

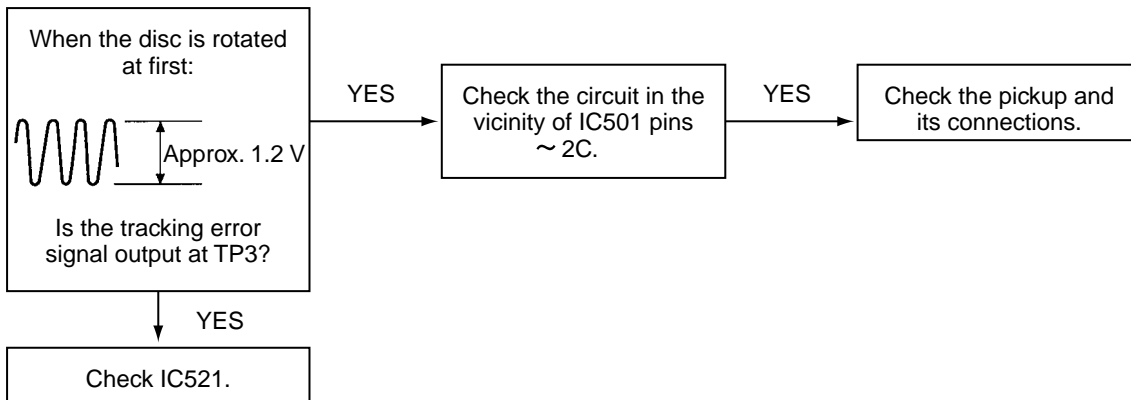



## ■ Signal processing section

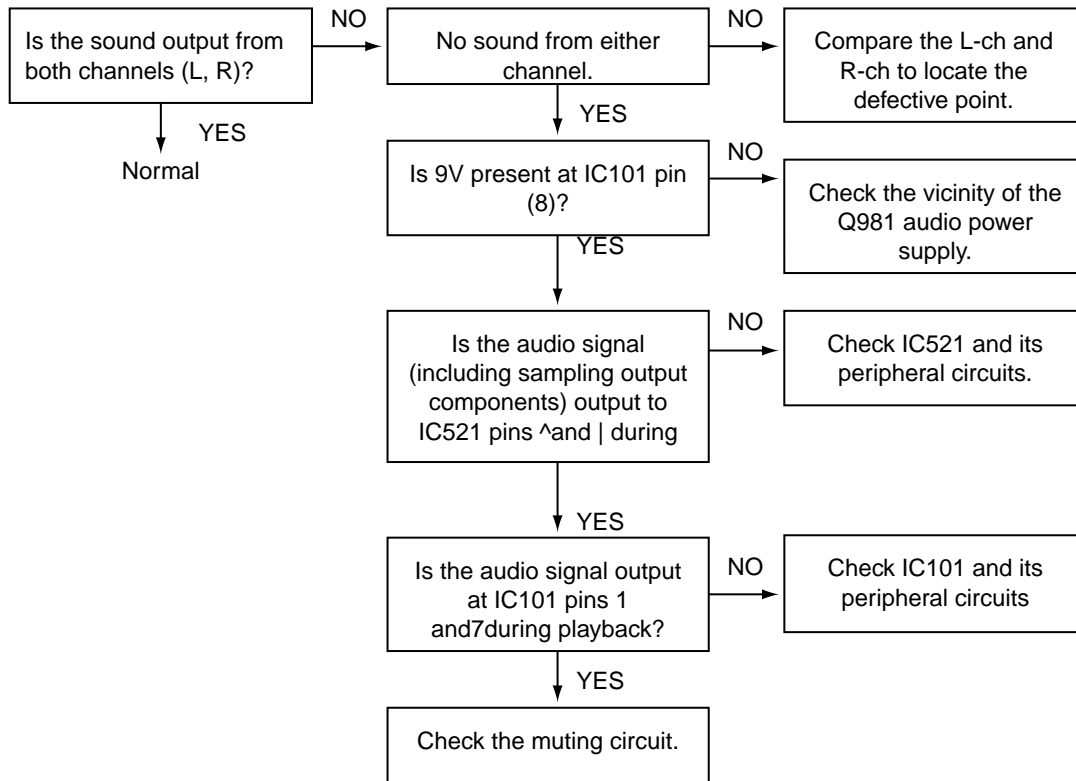

# Wiring connections

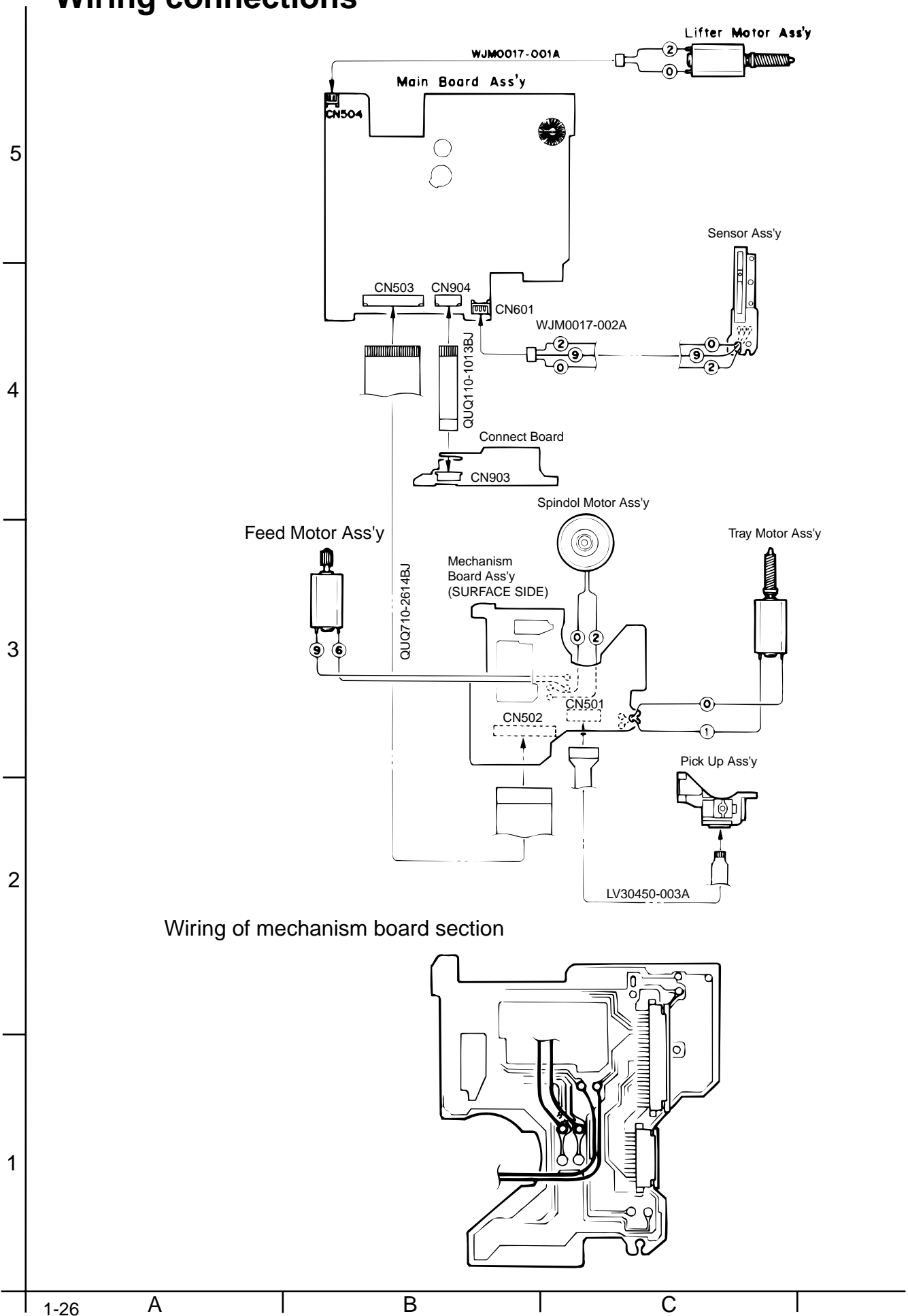

## Pickup replacement procedure

1. Remove the bottom cover, front panel and top cover from the exterior section.
2. Unplug the flexible ribbon wire from connector CN502 on the traverse mechanism PCB assembly.
3. Turn the rear slider and third gear in the lifter section counterclockwise until the traverse mechanism assembly is in the lowermost (bottom) position.
4. Unsolder the two wires (black and brown) connected to the tray motor.
5. Remove the two screws (1) from the round holes on the chassis R assembly to remove the lifter bracket (L).
6. Remove the lower rod.
7. Short-circuit the grounding point on the traverse mechanism PCB assembly of the lifter unit. Unsolder the wires connected to the spindle motor (red, black) and to the feed motor (blue, white) to lift the PCB assembly.  
Next, short-circuit the grounding point on the pickup main unit and unplug the pickup flexible PCB from CN501.
8. Remove the three fixing screws (2) from the round holes on the chassis R assembly to remove the traverse mechanism PCB assembly.
9. Remove the pickup shaft holder fixing screw (3) to remove the pickup assembly.

**Note:** When replacing the pickup, be sure to apply countermeasures against static electricity (grounding the operation table, wrist band and soldering iron). To remove it, first short-circuit the grounding point on the mechanism PCB, then lift the mechanism PCB assembly with CN501 connected. Next, short-circuit the grounding point on the pickup main unit, then unplug the pickup flexible PCB from connector CN501.

When reassembling, perform in the reverse order.

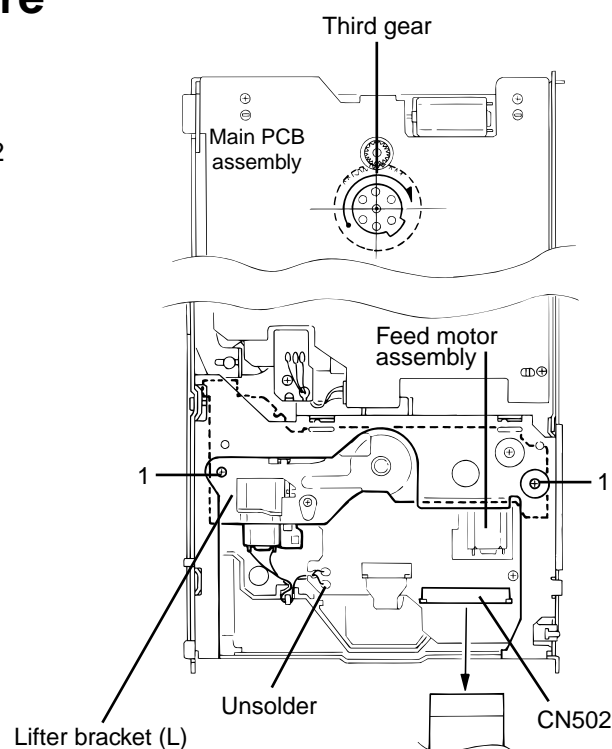

Fig. 49

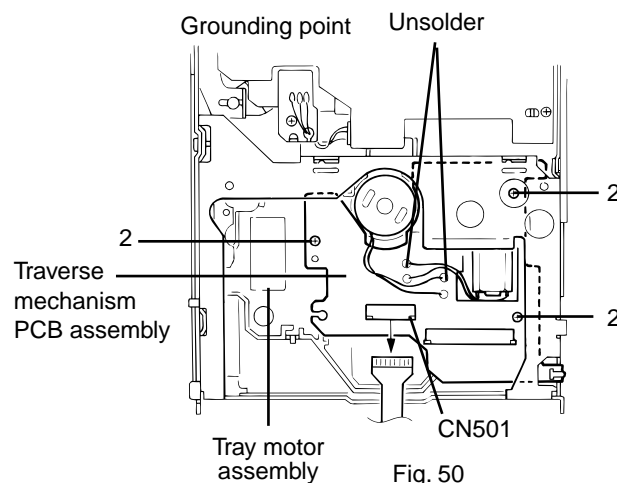

Fig. 50

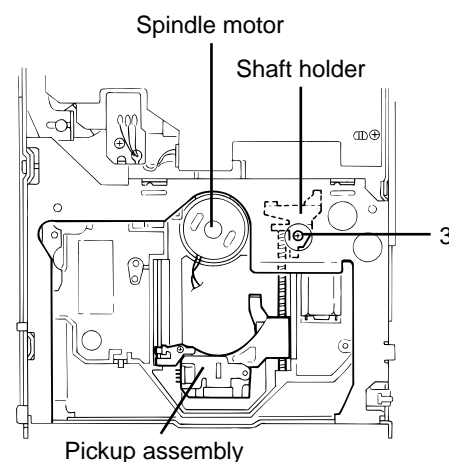

Fig. 51

10. Remove the two rack arm fixing screws (4).  
Pull out the feed slide shaft.  
Remove the shaft holder fixing screw (5).
11. When mounting the lifter bracket after replacing the pickup, shift the lifter unit lever approx. 30 mm towards the inside, then mount the lifter bracket.

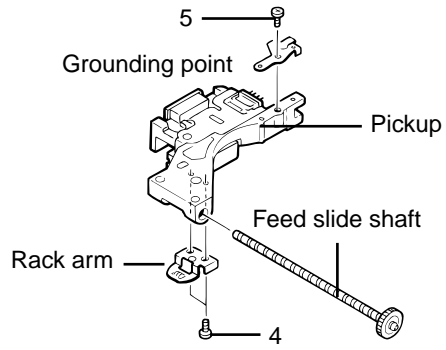

Fig. 52

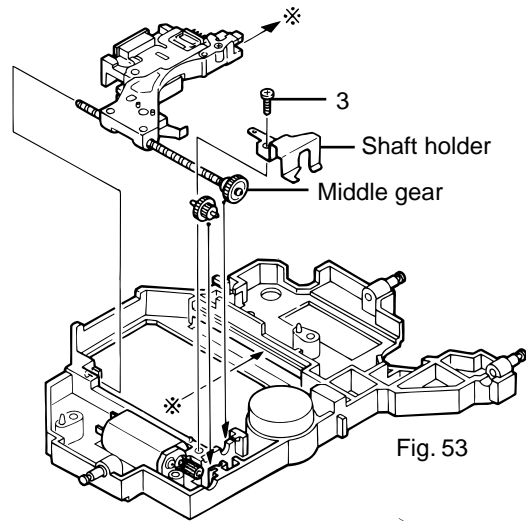

Fig. 53

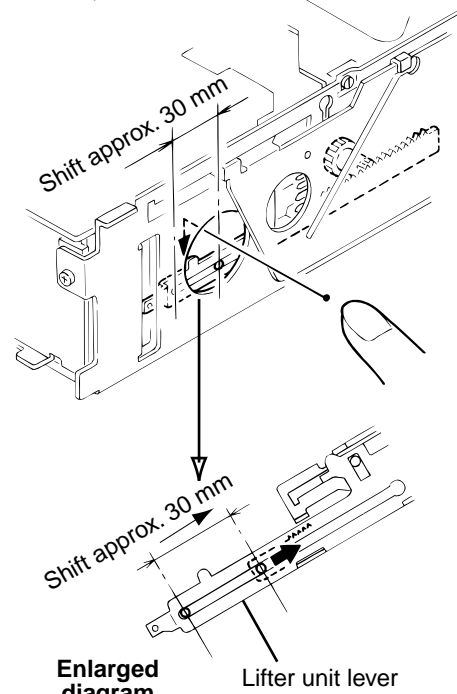
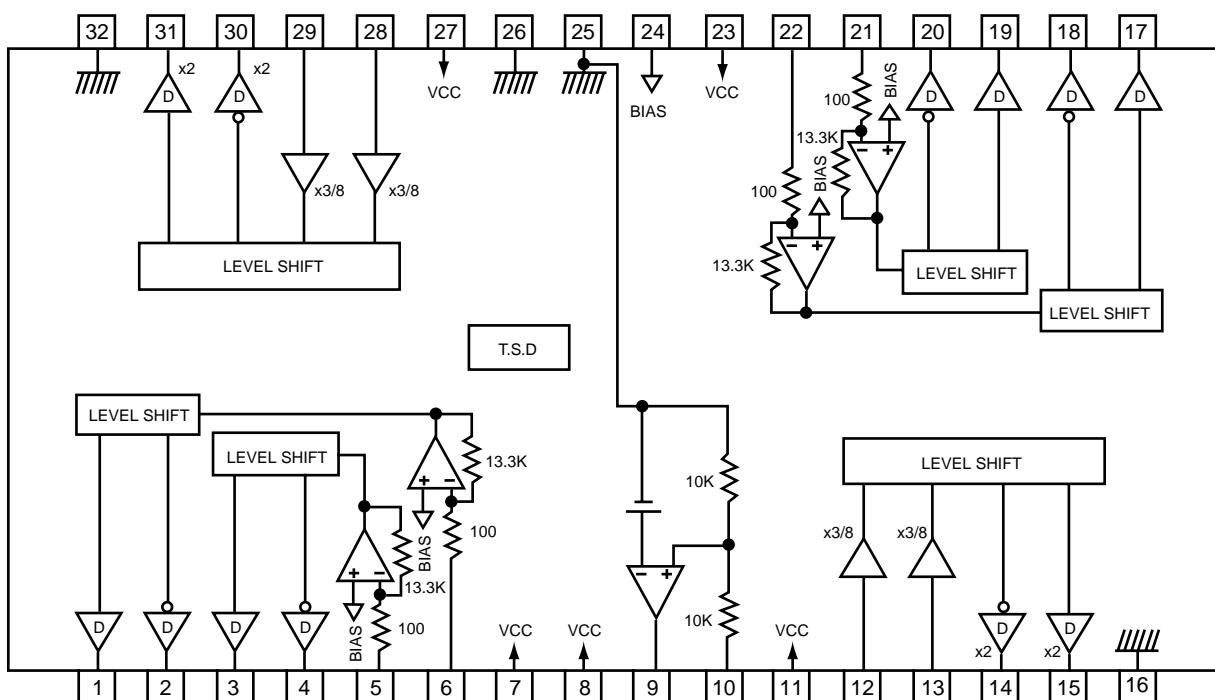

Fig. 54

# Description of major ICs

## ■ BA5926S(IC581):CD/POSITION/TRAY DRIVER

### 1.Terminal layout & Block diagram



T.S.D: Thermal shut down circuit

D: Driver buffer

Unit of resistor:[  $\Omega$  ]

### 2.Pin function

No.	Symbol	Function	No.	Symbol	Function
1	OUT1-	Driver CH1 negative output	17	OUT4-	Driver CH4 negative output
2	OUT+	Driver CH1 positive output	18	OUT4+	Driver CH4 positive output
3	OUT2-	Driver CH2 negative output	19	OUT5-	Driver CH5 negative output
4	OUT2+	Driver CH2 positive output	20	OUT5+	Driver CH5 positive output
5	IN 2	Driver CH2 input	21	IN 5	Driver CH5 input
6	IN 1	Driver CH1 input	22	IN 4	Driver CH4 input
7	VCC	Power supply	23	VCC	Power supply
8	VCC	Power supply	24	BIAS IN	Bias input
9	REG-B	Connect to external TR.BASE	25	GND	Substrate ground
10	REG OUT	Constant voltage output(5V)(*3)	26	GND	Substrate ground
11	VCC	Power supply	27	VCC	Power supply
12	IN3-R	driver CH3 reverse input	28	IN6-R	Driver CH6 reverse input
13	IN3-F	Driver CH3 forward input	29	IN6-F	Driver CH6 forward input
14	OUT3+	Driver CH3 positive output	30	OUT6+	Driver CH6 positive output
15	OUT3-	Driver CH3 negative output	31	OUT6-	Driver CH6 negative output
16	GND	ground	32	GND	ground

Note 1) Positive output and negative output of phasing with input.

Note 2) Loading positive output and loading negative output of phasing with mode.

\*3 Connect to external PNP transistor collector.

■ UPD780058GC-067(IC601):CPU

1. Terminal layout

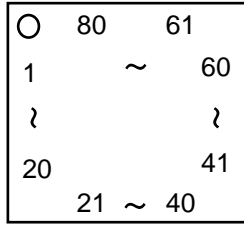

2. Block diagram

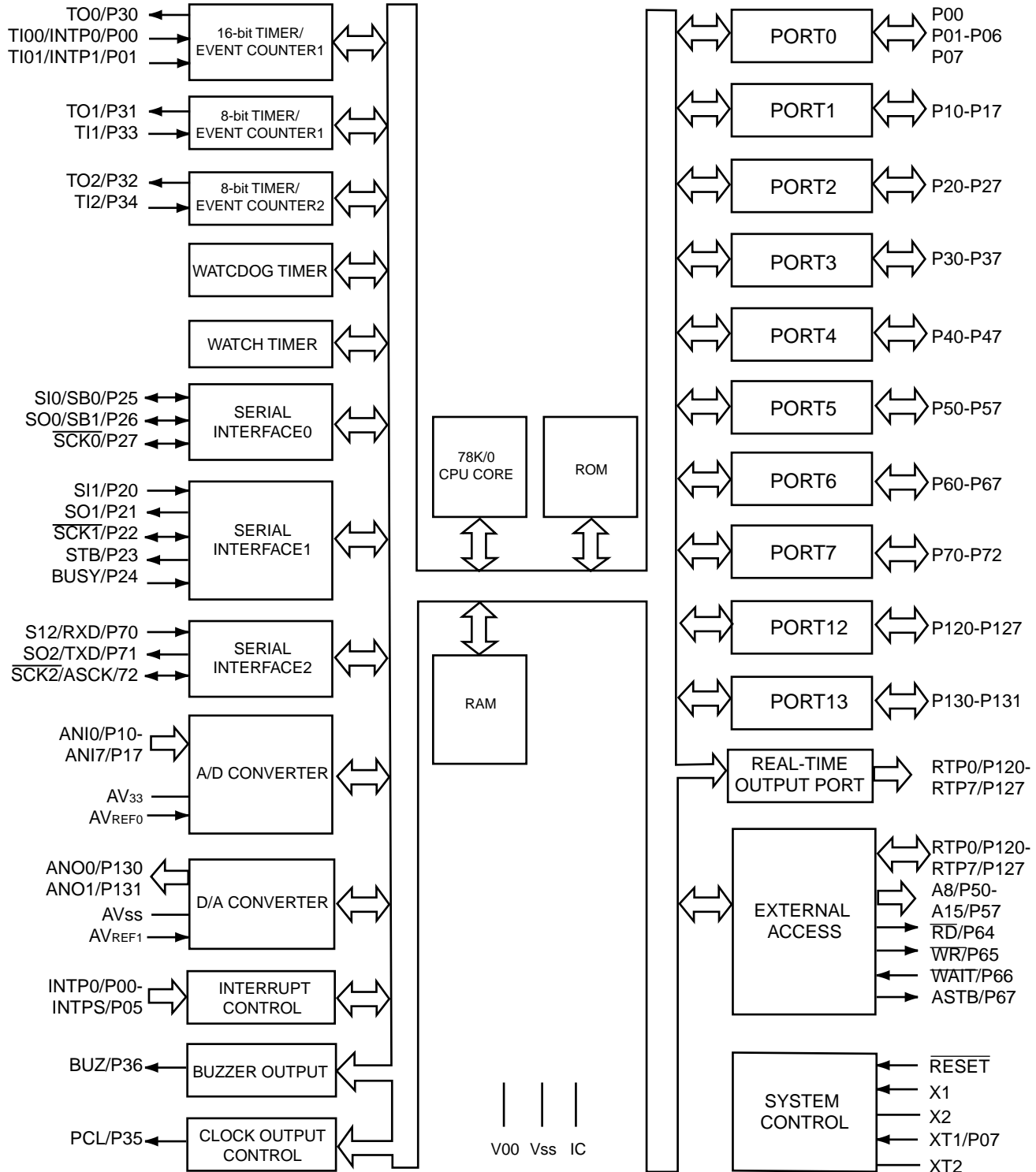

## 3.Pin function

UPD780058GC-067

Pin No.	PORT Name	I/O	Function	Active	Pin No.	PORT Name	I/O	Function	Active
1	LCDDA	O	LCD driver data output		41	NC	O	Unused output port	
2	LCDSCK	O	LCD driver clock output		42	NC	O	Unused output port	
3	LCDCE	O	LCD driver chip enable output		43	NC	O	Unused output port	
4	AVSS	-	Connect to ground		44	MAG IN	-	Magazine switch Lo:magazine inserted	L
5	ADCOUT	O	Power on Hi output. Low in stop mode.	H	45	TRAY IN	O	Tray retract switch Lo:retraction complete	L
6	NC	O	Unused output port		46	TRAY OUT	O	Tray extend switch Lo:extension complete	L
7	AVREF1	-	Connect to 5V		47	REST	I	Resr switch	L
8	NC	O	Unused output port		48	NC	O	Unused output port	
9	NC	O	Unused output port		49	EMPH	O	Emphasis select output Hi:on	H
10	CDCHECK	I	CD check mode input. Reset only.		50	NC	O	Unused output port	
11	EPROMDI	I/O	EEPROM data input		51	BUFF CONT	O	Buffer control output	L
12	EOROMDO	O	EEPROM data output. Hi durring input.		52	TEST RUN	I	Test running input	L
13	EPROMCK	I/O	EEPROM clock input/output		53	NC	O	Unused output port	
14	LED	O	Lifter LED output	H	54	NC	O	Unused output port	
15	BUS I/O	O	JVC bus input/output control(Lo:input)		55	NC	O	Unused output port	
16	BUS SI	I	JVC bus data input		56	MUTE	O	Mute output. When reverse of earlier audio mute. Mute power OR output	H
17	BUS SO	O	JVC bus data output						
18	BUS SCK	I/O	JVC bus clock input/output		57	STAGE	I	LCD,AD key,remote inhibit selector Low:inhidit	L
19	NC	O	Unused output port		58	NC	O	Unused output port	
20	NC	O	Unused output port		59	EPROM CLF	I	EEPROM clear input Functional only dunnng reset	L
21	NC	O	Unused output port		60	RESET	I	Reset input (includes flash write in function)	L
22	NC	O	Unused output port		61	REMOCON	I	Remote controller signal input	
23	NC	O	Unused output port		62	PWR DET	I	Memory power detect input	
24	NC	O	Unused output port		63	PWR SW	I	CRTL+B detect input	
25	BUSOUT	O	JVC bus output	H	64	BUS INT	I	JVC bus com start interrupt input	
26	CD ON	O	CD power control Hi:on	H	65	EJECT	I	Eject key input	
27	PWR CONT	O	Power supply control output Hi:on	H	66	NC	I	Unused output port	L
28	POSMO+	O	Position motor control output		67	VSS0	-	Connect to ground	
29	POSMO-	O	Position motor control output		68	VDD1	-	Connect to 5V	
30	TRAYMO+	O	Tray motor control output		69	X2	O	Oscillater (4.19430 MHz)	
31	TRAYMO-	O	Tray motor control output		70	X1	I	Oscillater (4.19430 MHz)	
32	BUCK	O	CD LSI data clock		71	IC	-	Connect to ground	
33	VSS1	-	Connect to ground		72	XT2	O	Open	
34	LSI RESET	O	CD LSI reset	L	73	XT1	I	Connect to VDD	
35	CCE	O	CD LSI chip enable		74	VDD	-	Connect to 5V	
36	BUS0	I/O	CD LSI data 0(open drain)		75	AVREF0	-	Connect to ADCONT	
37	BUS1	I/O	CD LSI data 1 (open drain)		76	L SENSOR	I	Linear sensor input(8 bit A/D input)	
38	BUS2	I/O	CD LSI data 2 (open drain)		77	KEY1	I	Key input 1 (8 bit A/D input)	
39	BUS3	I/O	CD LSI data 3 (open drain)		78	KEY2	I	Key input 2 (8 bit A/D input)	
40	NC	O	Unused output port		79	KEY3	I	Key input 3 (8 bit A/D input)	
					80	KEY0	I	Key input 0 (8 bit A.D input)	

**TC9462F(IC521): DSP&DAC**

1.Pin layout & Block Diagram

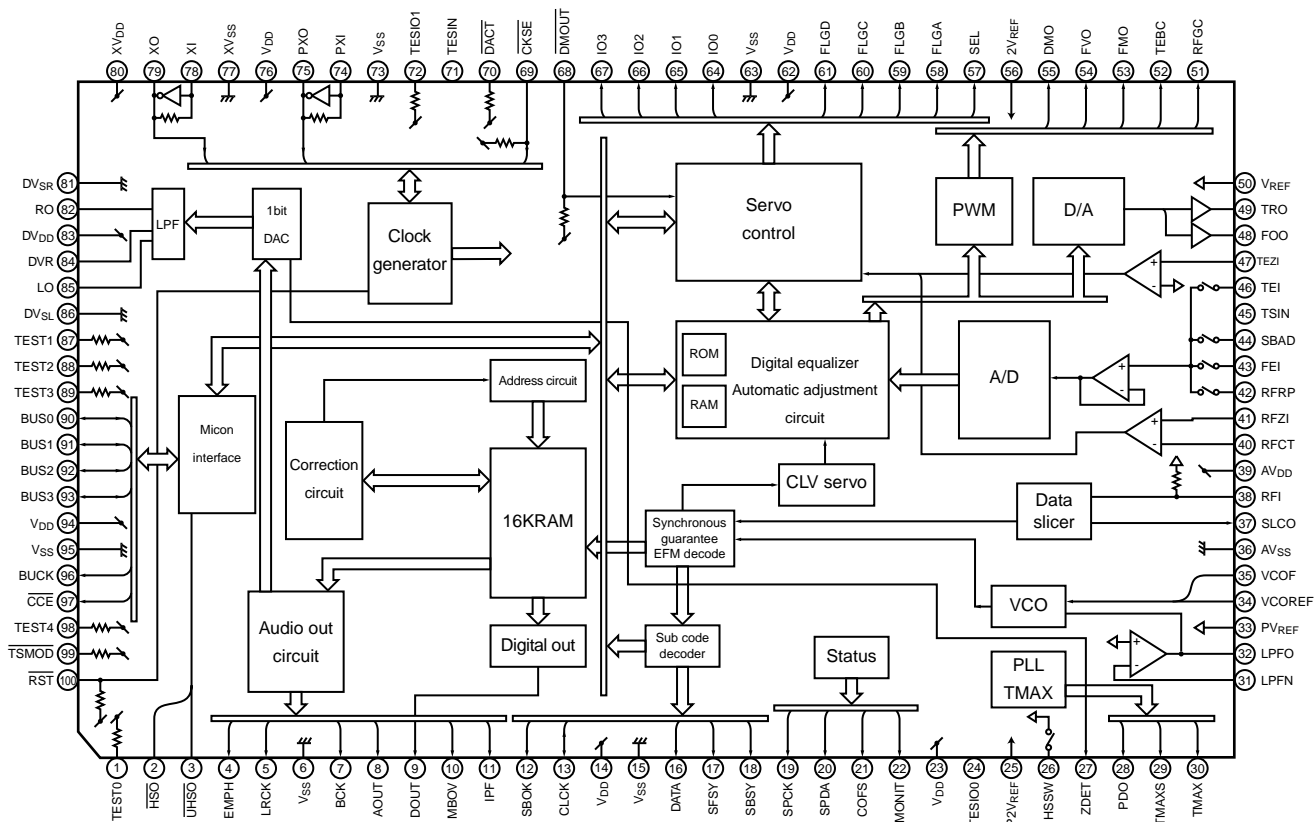

2.Pin function

PIN No.	SYMBOL	I/O	FUNCTIONAL DESCRIPTION	REMARKS															
1	TEST0	I	Test mode terminal. Normally, Keep at open.	With pull-up resistor.															
2	HSO	O	Playback speed mode flag output terminal. <table border="1" style="margin-left: 20px;"> <tr> <th>UHSO</th> <th>HSO</th> <th>PLAYBACK SPEED</th> </tr> <tr> <td>H</td> <td>H</td> <td>Normal</td> </tr> <tr> <td>H</td> <td>L</td> <td>2 times</td> </tr> <tr> <td>L</td> <td>H</td> <td>4 times</td> </tr> <tr> <td>L</td> <td>L</td> <td>--</td> </tr> </table>	UHSO	HSO	PLAYBACK SPEED	H	H	Normal	H	L	2 times	L	H	4 times	L	L	--	--
UHSO	HSO	PLAYBACK SPEED																	
H	H	Normal																	
H	L	2 times																	
L	H	4 times																	
L	L	--																	
3	UHSO	O																	
4	EMPH	O	Subcode Q data emphasis flag output terminal. Emphasis ON at "H" level and OFF at "L" level. The output polarity can invert by command.	--															
5	LRCK	O	Channel clock output terminal. (44.1kHz) L-ch at "L" level and R-ch at "H" level. the output polarity can invert by command.	--															
6	VSS	--	Digital GND terminal.	--															
7	BCK	O	Bit clock output terminal. (1.4122MHz)	--															
8	AOUT	O	Audio data output terminal.	--															
9	DOUT	O	Digital data output terminal.	--															
10	MBOV	O	Buffer memory over signal output terminal. Over at "H" level.	--															
11	IPF	O	Correction flag output terminal. At "H" level, AOUT output is made to correction impossibility by C2 correction processing.	--															
12	SBOK	O	Subcode Q data CRCC check adjusting result output terminal. The adjusting result is OK at "H" level.	--															
13	CLCK	I/O	Subcode P~W data reabout clock input/output terminal. This terminal can select by command bit.	--															
14	VDD	--	Digital power supply voltage terminal.	--															
15	VSS	--	Digital GND terminal.	--															
16	DATA	O	Subcode P~W data output terminal.	--															
17	SFSY	O	Play-back frame sync signal output terminal.	--															
18	SBSY	O	Subcode block sync signal output terminal.	--															
19	SPCK	O	Processor status signal reabout clock output terminal.	--															
20	SADA	O	Processor status signal output terminal.	--															
21	COFS	O	Correction frame clock output terminal. (7.35kHz)	--															
22	MONIT	O	Internal signal (DSP internal flag and PLL clock) output terminal. Selected by command. This terminal output the text data with serial by command.	--															
23	VDD	--	Digital power supply voltage terminal.	--															
24	TESIO0	I	Test input/output terminal. Normally, keep at "L" level. The terminal that inputted the clock for read of text data by command.	--															
25	P2VREF	--	PLL double reference voltage supply terminal.	--															



## 2.Pin Function

TC9462F(2/2)

Pin No.	Symbol	I/O	Function
40	RFCT	I	RFRP signal center level input terminal
41	RFZI	I	RFRP zero cross input terminal
42	RFRP	I	RF ripple signal input terminal
43	FEI	I	Focus error signal input terminal
44	SBAD	I	Sub-beam adder signal input terminal
45	TSIN	I	Test input terminal Normally, keep at "vref" level
46	TEI	I	Tracking error signal input terminal. Take in at tracking servo ON.
47	TEZI	I	Tracking error zero cross input terminal
48	FOO	O	Focus servo equalizer output terminal
49	TRO	O	Tracking servo equalizer output terminal
50	VREF	-	Analog reference voltage supply terminal
51	RFGC	O	RF amplitude adjustment control signal output terminal
52	TEBC	O	Tracking balance control signal output terminal
53	FMO	O	Feed equalizer output terminal
54	FVO	O	Speed error signal or feed search equalizer output terminal
55	DMO	O	Disk equalizer output terminal (PWM carrier=88.2kHz for DSP, Synchronize to PXO)
56	2VREF	-	Analog double reference voltage supply terminal
57	SEL	O	APC circuit ON/OFF indication signal output terminal
58~61	FLGA~D	O	External flag output terminal for internal signal
62	VDD	-	Digital power supply voltage terminal
63	VSS	-	Digital GND terminal
64~67	IO0~3	I/O	General I/O terminal
68	DMOUT	I	This terminal control IO0~IO3 terminal
69	CKSE	I	Normally, keep at open
70	DACT	I	DAC test mode terminal. Normally, keep at open
71	TESIN	I	Test input terminal, Normally, keep at "L" level
72	TESIO1	I	Test input/output terminal. Normally, keep at "L" level
73	VSS	-	Digital GND terminal
74	PXI	I	Crystal oscillator connecting input terminal for DSP
75	PXO	O	Crystal oscillator connecting output terminal for DSP
76	VDD	-	Digital power supply voltage terminal
77	XVSS	-	Oscillator GND terminal for system clock
78	XI	I	Crystal oscillator connecting input terminal for system clock
79	XO	O	Crystal oscillator connecting output terminal for system clock
80	XVDD	-	Oscillator power supply voltage terminal for system clock
81	DVSR	-	Analog GND terminal for DA converter (Rch)
82	RO	O	R channel data forward output terminal
83	DVDD	-	Analog supply voltage terminal for DA converter
84	DVR	-	Reference voltage terminal for DA converter
85	LO	O	L channel data forward output terminal
86	DVSL	-	Analog GND terminal for DA converter (Lch)
87~89	TEST1~3	I	Test mode terminal . Normal keep at open
90~93	BUS0~3	I/O	Micon interface data input/output terminal
94	VDD	-	Digital power supply voltage terminal
95	VSS	-	Digital GND terminal
96	BUCK	I	Micon interface clock input terminal
97	CCE	I	Command and data sending/receiving chip enable signal input terminal
98	TEST4	I	Test mode terminal. Normal, keep at open
99	TSMOD	I	Local test mode selection terminal
100	RST	I	Reset signal input terminal. Reset at "L" level

■ TA2109F-X (IC501) : RF amp.

1. Pin layout

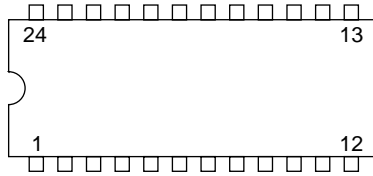

2. Block diagram

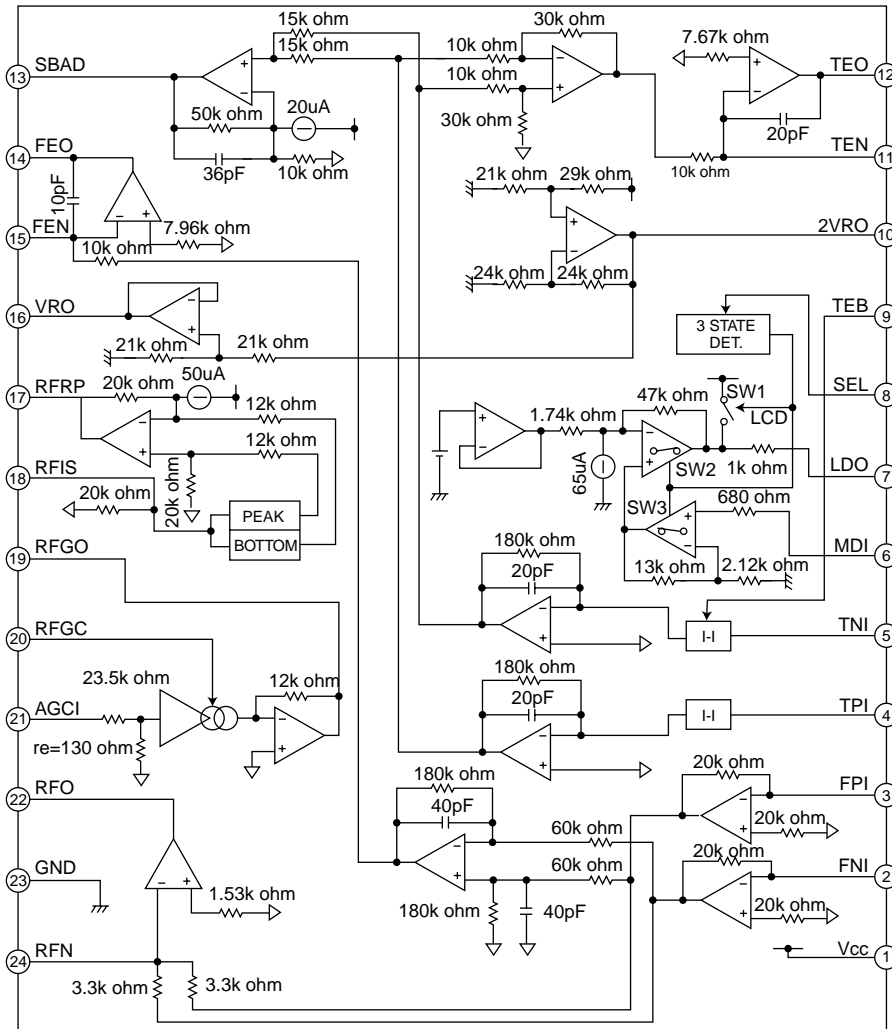

3. Pin function

Pin No.	Symbol	I/O	Pin function	Pin No.	Symbol	I/O	Pin function
1	Vcc	-	Power supply input terminal	13	SBAD	O	Sub beam adder signal output terminal
2	FNI	I	Main beam I-V amp input terminal	14	FEO	O	Focus error signal output terminal
3	FPI	I	Main beam I-V amp input terminal	15	FEN	I	FE amp negative input terminal
4	TPI	I	Sub beam I-v input terminal	16	VRO	O	Reference voltage (VREF) output terminal
5	TNI	I	Sub beam I-V input terminal	17	RFRP	O	Track count signal output terminal
6	MDI	I	Monitor photo diode amp input terminal	18	RFIS	I	RFRP detect circuit input terminal
7	LDO	O	Laser diode amp output terminal	19	RFGO	O	RF gain signal output terminal
8	SEL	I	Laser diode control signal input terminal	20	RFGC	I	RF amplitude adj. control signal input terminal
9	TEB	I	T. error balance adj. signal input terminal	21	AGCI	I	RF signal amplitude adj. amp input terminal
10	2VRO	O	Reference voltage output terminal	22	RFO	O	RF signal output terminal
11	TEN	I	TE amp negative input terminal	23	GND	-	Ground terminal
12	TEO	O	TE error signal output terminal	24	RFN	I	RF amp negative input terminal

■ BA15218F-XE (IC101) : CD LPF

1. Pin layout

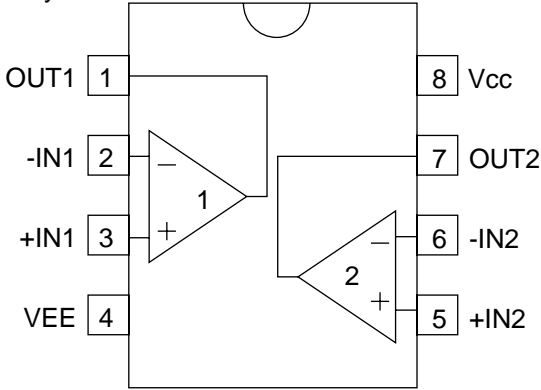

2. Block diagram

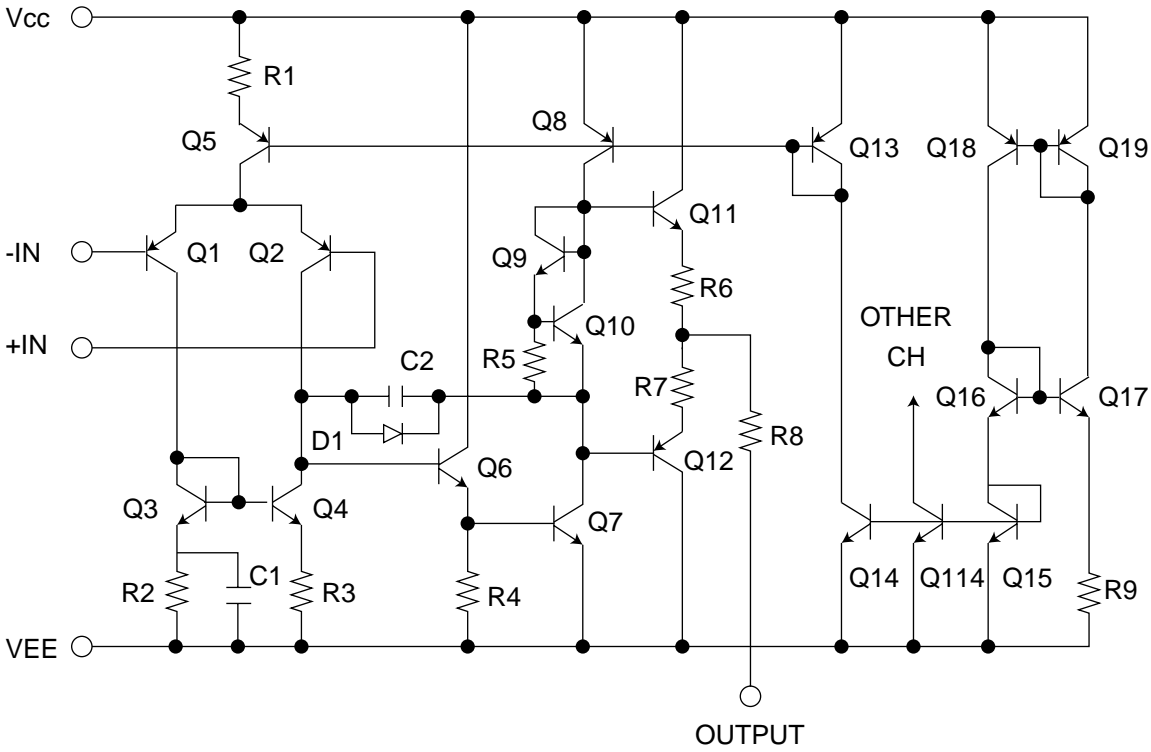

■ BR24C01AF(IC604):EP ROM

1.Terminal Layout

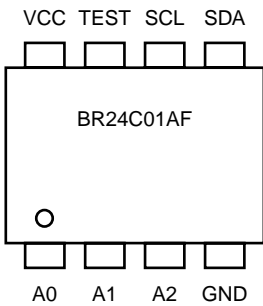

2.Block Diagram

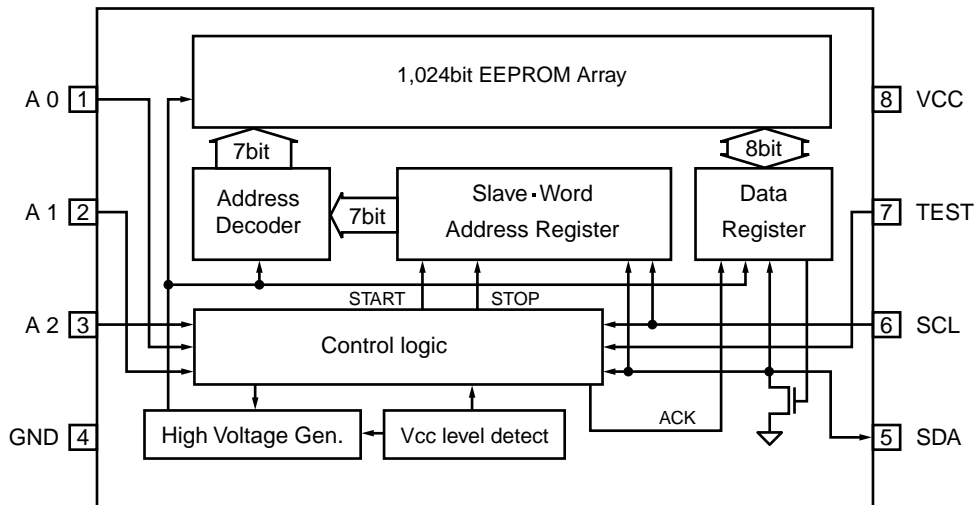

3.Pin Function

Symbol	I/O	Function
VCC	-	Power Supply
GND	-	Ground(OV)
A1·A2·A3	I	Slaves Address Set(Pin)
SCL	I	Serial Clock Input
SDA	I/O	Slaves and Word Address,Serial Data Input, Serial Data Output(*)
TEST	I	Ground

(\*)An open drain output requires a pull-up resistor.

■ HD74HC126FP-X (IC651) : Buffer

1.Terminal layout

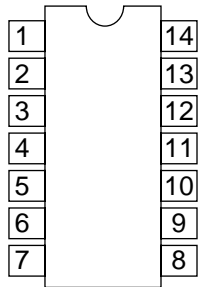

3.Pin function

Input		Output
C	A	Y
L	X	Z
H	L	H
H	H	L

2.Block diagram

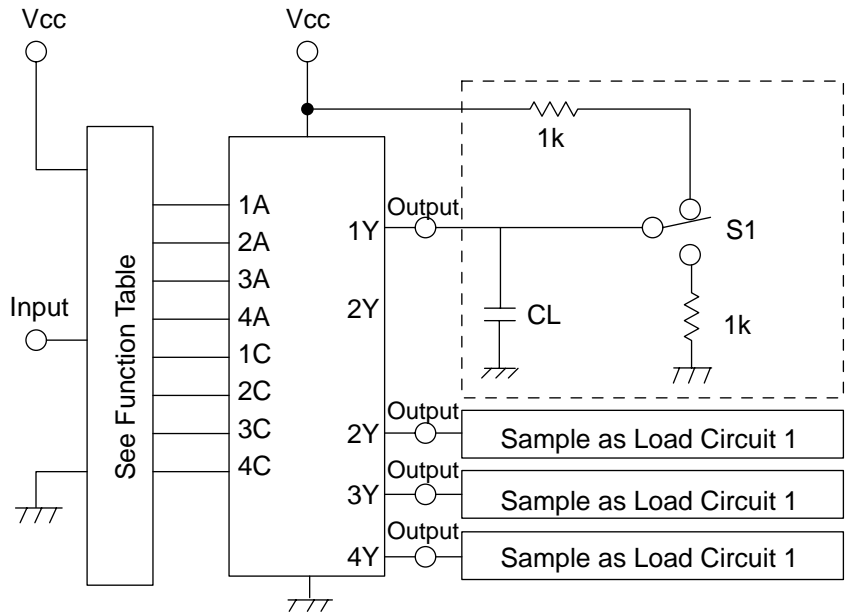

■ IC-PST600M/G/-W1197(IC602):Reset

1.Terminal layout

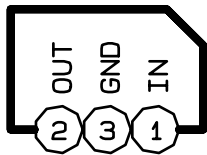

2.Block diagram

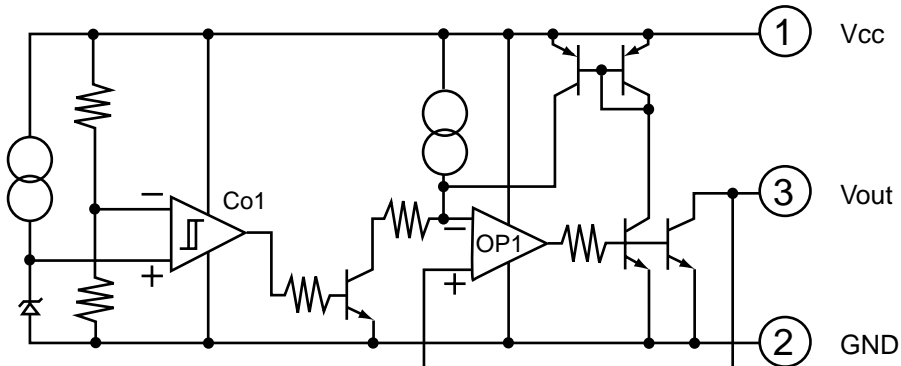

**JVC**

VICTOR COMPANY OF JAPAN, LIMITED  
MOBILE ELECTRONICS DIVISION  
PERSONAL & MOBILE NETWORK BUSINESS UNIT. 10-1,1Chome,Ohwatari-machi,Maebashi-city,Japan